

# NAVAL POSTGRADUATE SCHOOL

## Monterey, California



MANPOWER PROCUREMENT POLICIES, GROUND FORCE  
STRUCTURES, AND REGISTRATION SYSTEMS:  
DENMARK, THE FEDERAL REPUBLIC OF GERMANY,  
NORWAY, AND THE UNITED KINGDOM

Ragnhild Sohlberg

February 1981

Approved for public release; distribution unlimited.  
Prepared for: Naval Postgraduate School  
Monterey, CA 93940

NAVAL POSTGRADUATE SCHOOL  
Monterey, California

Rear Admiral J. J. Ekelund  
Superintendent

Jack R. Borsting  
Provost

Reproduction of all or part of this report is authorized.  
This report was prepared by:

REPORT DOCUMENTATION PAGE		READ INSTRUCTIONS BEFORE COMPLETING FORM	
1. REPORT NUMBER NPS-64-81-001	2. GOVT ACCESSION NO.	3. RECIPIENT'S CATALOG NUMBER	
4. TITLE (and Subtitle) MANPOWER PROCUREMENT POLICIES, GROUND FORCE STRUCTURES, AND REGISTRATION SYSTEMS: DENMARK, THE FEDERAL REPUBLIC OF GERMANY, NORWAY, AND THE UNITED KINGDOM		5. TYPE OF REPORT & PERIOD COVERED Final Report	
		6. PERFORMING ORG. REPORT NUMBER	
7. AUTHOR(s) Ragnhild Sohlberg		8. CONTRACT OR GRANT NUMBER(s)	
9. PERFORMING ORGANIZATION NAME AND ADDRESS Naval Postgraduate School Monterey, California 93940		10. PROGRAM ELEMENT, PROJECT, TASK AREA & WORK UNIT NUMBERS	
11. CONTROLLING OFFICE NAME AND ADDRESS Defense Resources Management Education Center Naval Postgraduate School Monterey, California 93940		12. REPORT DATE February 1981	
		13. NUMBER OF PAGES 100	
14. MONITORING AGENCY NAME & ADDRESS (if different from Controlling Office)		15. SECURITY CLASS. (of this report) Unclassified	
		15a. DECLASSIFICATION/DOWNGRADING SCHEDULE	
16. DISTRIBUTION STATEMENT (of this Report) Approved for public release, distribution unlimited			
17. DISTRIBUTION STATEMENT (of the abstract entered in Block 20, if different from Report)			
18. SUPPLEMENTARY NOTES			
19. KEY WORDS (Continue on reverse side if necessary and identify by block number)			
Ground forces	Draft	Total Defense	Denmark
NATO Europe	Mobilization	Force Reductions	Norway
Manpower	MBFR	United Kingdom	
Registration	Reserves	Federal Republic of Germany	
Conscription	Standardization	Military balance assessment	
20. ABSTRACT (Continue on reverse side if necessary and identify by block number)			
Compares manpower policies, peacetime force structures, and the character and time-phased availability of reserve forces in Denmark, the Federal Republic of Germany, Norway, and the United Kingdom. Information provided by standard comparative sources is insufficient for military balance assessments, as baselines for force reduction negotiations, and for reinforcement planning. This paper was based on national publications and documents and direct assistance from European defense authorities and experts. Differences in countries' history and conditions have led to a diversity of manpower policies and force structures--which may			

#20--limit the feasibility and desirability of standardization. Universality of military conscription is at best approximated. Lengths of regular duty and reserve obligations vary within nations. The peacetime armies of Denmark, West Germany, and Norway have 30, 51, and 80 percent conscripts, respectively. Longer term volunteers and conscripts with extended obligations tend to fill complex tasks. These countries have significant mobilization potentials with relatively high readiness.





PREFACE

This paper was partly prepared under the sponsorship of the Directorate for Mobilization and Deployment Planning, the Office of the Assistant Secretary of Defense (Manpower, Reserve Affairs, and Logistics)--OASD(MRA&L).

The research began six years ago as a comparative study of manpower policies and issues in the ground forces of seven northern and central European NATO countries. As it became apparent that these nations have adopted a variety of manpower policies and ground force structures depending on internal and external national conditions, earlier studies were expanded to include a detailed analysis of Danish and Norwegian ground force structures as well as an analysis of the transition and mobilization problems associated with changing from a peacetime to a wartime organization.

This present study expands on earlier comparisons by providing additional information on Danish and Norwegian manpower policies and ground force structures as well as providing parallel information for the Federal Republic of Germany (West Germany) and for the United Kingdom. A well-functioning registration system is necessary to support conscription and to ensure a rapid mobilization of reservists, therefore the national and military registration systems are also included. Because present policies are influenced by history and traditions, relevant historical developments are presented.

Because this paper is part of continuing research, comments and suggestions are encouraged.

SUMMARY

Comparative studies of manpower policies, peacetime force structures, and the character and time-phased availability of augmentation or reserve forces are important for several reasons. First, such studies are necessary ingredients in building and maintaining more efficient NATO force structures as well as in military balance assessments. Second, a useful baseline for negotiating meaningful force reductions must include both peacetime strengths as well as the time-phased availability of wartime augmentations. Finally, studies of other nations' policies can generate ideas for alternative policies and yield insight into implementation problems.

However, information provided by current, standard comparative sources is insufficient for dealing with these issues. Consequently, relative to hardware, the manpower dimensions of force structures have been given little comparative analytic attention.

This study, part of continuing research, is based on national publications and documents as well as on direct assistance from defense authorities and experts in Europe. Its organization places a discussion of major manpower issues first, followed by a four country comparative examination of manpower procurement policies, manpower dimensions of ground force structures, and national and military manpower registration systems. A part of this examination is a brief overview of relevant historic facts for each nation.

The comparison of Denmark, the Federal Republic of Germany (West Germany), Norway, and the United Kingdom (Britain), showed a diversity of policies with respect to force structures, manpower policies, reserve utilization, and the military role of women. It is also clear that the technology selected by individual nations for their ground forces is influenced by national conditions as well as by manpower policies.



There exists no apparent evidence that NATO membership has significantly influenced these four nations' manpower policies and ground force structures. Analysis of their policies illustrates that their contrasting arrangements are responses to extremely different conditions of population density, terrain, and internal communications as well as to differences in geo-strategic location, traditions, and defense missions.

Except for the United Kingdom, these countries have retained conscription as a major manpower procurement method. Denmark, the Federal Republic of Germany, and Norway--which to varying degrees have served as battlegrounds and primarily are concerned with territorial defense--have historically relied on conscription. A reduction or elimination of the conscripted component has been debated, but in general the concept has wide acceptance and is seen as necessary and desirable.

Neither Denmark, West Germany, nor Norway have universal military conscription--respectively, approximately 30, 58, and somewhat over 60 percent of male age cohorts complete regular active duty in one of the armed services. The lengths of regular duty and reserve obligation also vary from nation to nation.

Attempts to approximate universal conscription combined with prolonged reserve obligation tend to result in relatively inflexible or rigid force structures. While continuity of policies and practices has advantages, this may also inhibit changes which otherwise would have been made.

The peacetime armies of Denmark and West Germany have 30 and 51 percent conscripts, respectively. Consequently, their armies could be characterized as volunteer armies with conscript components. Norway, on the other hand, has 80 percent conscripts in the

peacetime army. Today's conscripts, however, are better qualified upon induction than ever before. The training period is also used more effectively. In addition, part of the conscripted component consists of "quasi volunteers"--many have either been obligated to or have volunteered for training over and above the minimum.

All four nations plan to mobilize a significant number of reservists in case of crisis. Denmark and Norway must mobilize approximately 90 percent of its full wartime potential. Corresponding percentages for West Germany and Britain are 65 and 56, respectively. The readiness of this mobilization potential is relatively high, but Norway and the United Kingdom face potentially significant deployment problems.

In the four study nations, all field army reservists have prior service; i.e., all have completed a regular tour of duty. Men and women without prior service, however, may volunteer to the Danish Home Guard and to the British Territorial Army and the Ulster Defence Regiment.

Women have a limited role in these nations' armed services. But their role is expanding, not primarily because of "equal rights" pressures, but because male age cohorts are shrinking. None of these nations currently obligate women for mobilization assignments upon completion of regular duty. However, in some cases they may volunteer for mobilization roles.

Military technology increasingly requires more extensive training for operation or for maintenance. To varying degrees, this has been taken into account in force structures and utilization of manpower. Longer term volunteers and conscripts with extended obligations are increasingly trained to fill complex tasks.

Rationalization, standardization, and interoperability are promoted as means to deal with NATO resource dilemmas. However, the diversity of manpower policies and force structures may limit both the feasibility and the desirability of standardization. For example, the time required to introduce new equipment as well as replacement rates vary from nation to nation. Topography, climate and soil conditions as well as manpower policies and practices put requirements on technical characteristics. It is also possible that diversity means strength rather than weakness.

A multi-dimensional assessment of manpower policies and manpower dimensions of ground force structures is complicated, costly, time-consuming, and requires extensive data search or improved data bases. However, such studies will result in more meaningful comparisons of national capabilities and evaluations of military balances, in more useful baselines for force reduction negotiations, and may generate ideas for more efficient and effective force structures.

ACKNOWLEDGMENTS

Many people helped produce this paper. The research for this and earlier studies would have been impossible without the kind assistance of several European military and civilian defense experts who generously shared their expertise with me. The list of names is too long to permit many individual mentions, and several have been acknowledged in earlier reports. The help they provided is certainly also reflected here.

At this time I want to acknowledge Major F. R. Vadmand, formerly of the Army Staff, Danish Defense Command; OTL i.G. Gerhard Ludwig, BMVg FÜ S IV 2, Bonn, who in person and by correspondence over the last two years patiently helped me understand the West German policies and practices; Lt.Col. Birger Setsaas, Army Staff, Norwegian Defence Command, who over the last five years instructed me on basic force structures as well as on specific Norwegian policies and practices; Lt.Col. R. N. P. Reynolds, AG (Mob), Ministry of Defence, who during my visit to London in September 1980 kindly provided me with information on the British ground forces and mobilization system; and Mr. J. Pitt-Brooke, Defence Secretariat 14, Ministry of Defence, London, who assisted me during my visit in September 1980 and later provided detailed commentary on an earlier version of this paper.

I also gratefully acknowledge Professor William A. Mauer of the Naval Postgraduate School for his valuable comments on prior reports and for his review of the present paper.

Mary Andrews deserves specific mention not only for excellent typing but also for the efficient and good spirited manner in which she performed several modifications.

I am also indebted to Eva Zaidain for transforming several of my awkwardly sketched figures into the professional-looking versions included in this paper.

I, of course, bear sole responsibility for any remaining misinterpretations as well as for the comparative conclusions drawn from the material.

CONTENTS

## FRONTISPIECE MAP

PREFACE . . . . .	i
SUMMARY . . . . .	ii
ACKNOWLEDGMENTS . . . . .	vi
LIST OF FIGURES . . . . .	ix
LIST OF TABLES. . . . .	x

## Section

I. INTRODUCTION. . . . .	1
Organization of Study . . . . .	1
Why Study non-U.S. NATO Manpower Policies?. . . . .	1
Theoretical Framework for Analyzing Manpower	
Policies and Force Structures . . . . .	3
Peacetime and Wartime Organizations . . . . .	3
Manpower Procurement Alternatives . . . . .	5
Tradeoff Between Recruits Required and Length of	
Regular Active Duty . . . . .	9
Cost-Effectiveness of Manpower. . . . .	9
Total Force Analysis. . . . .	14
II. NATIONAL SYSTEMS. . . . .	17
Denmark . . . . .	17
Background. . . . .	17
Manpower Procurement Policies . . . . .	18
Peacetime and Wartime Ground Force Structure. . . . .	21
Registration System . . . . .	28
The Federal Republic of Germany . . . . .	29
Background. . . . .	29
Manpower Procurement Policies . . . . .	32
Peacetime and Wartime Ground Force Structure. . . . .	34
Registration System . . . . .	41

Norway. . . . .	45
Background. . . . .	45
Manpower Procurement Policies . . . . .	47
Peacetime and Wartime Ground Force Structure. . . . .	51
Registration System . . . . .	57
The United Kingdom. . . . .	58
Background. . . . .	58
Manpower Procurement Policies . . . . .	64
Peacetime and Wartime Ground Force Structure. . . . .	70
Registration System . . . . .	77
III. SUMMARY COMPARISON AND CONCLUSIONS. . . . .	79
Peacetime and Wartime Organizations and Deployment. . . . .	79
Denmark . . . . .	79
The Federal Republic of Germany . . . . .	82
Norway. . . . .	83
The United Kingdom. . . . .	83
Time-phased Availability. . . . .	84
Manpower Policies . . . . .	85
Procurement Policies. . . . .	85
Regular and Reserve Policies. . . . .	86
Conclusions . . . . .	90
Consequences of Diverse Manpower Policies and Force Structures. . . . .	94
NATO Coordination of Equipment Procurement. . . . .	94
Military Balance Assessments and Force Reduction Negotiations. . . . .	95
REFERENCES. . . . .	97

LIST OF FIGURES

1	Hypothetical Total Force structures . . . . .	4
2	Alternative defense manpower categories . . . . .	6
3	Tradeoff between length of regular active duty and annual accession requirements (given constant force size). . .	10
4	Hypothetical cost-effectiveness time-profile of a serviceman. . . . .	11
5	Consequences of changing the length of regular active duty (Total Force analysis) . . . . .	15
6	Manpower flows through the Danish Ground Forces . . . . .	20
7	The Danish Armoured Infantry Brigade. . . . .	24
8	Manpower flows through the West German Army (Field Army and Territorial Army) . . . . .	33
9	The West German Peacetime and Wartime Brigade Structure .	39
10	The new Territorial Army. . . . .	42
11	Manpower flows through the Norwegian Ground Forces. . . .	48
12	The Norwegian Infantry Brigade. . . . .	54
13	Manpower flows through the British Ground Forces. . . . .	65
14	The British Army Force Structure. . . . .	73

LIST OF TABLES

1	Denmark's Army Wartime Force Structure . . . . .	22
2	The Federal Republic of Germany: Army Structure 4 . . . .	36-37
3	Norway's Army Wartime Force Structure. . . . .	53
4	The United Kingdom: Ground Forces Personnel . . . . .	71
5	The British Army: Deployment and Organization . . . . .	72
6	Ground Forces Manpower: Denmark, the Federal Republic of Germany, Norway, and the United Kingdom. . . . .	80-81
7	Minimum Military Obligation. . . . .	87
8	Reserve Training: Denmark, the Federal Republic of Germany, Norway, and the United Kingdom. . . . .	89



## I. INTRODUCTION

### ORGANIZATION OF STUDY

This introductory chapter briefly discusses some of the manpower issues facing nations and alliances today and outlines one theoretical framework for analyzing national manpower policies and force structures.

The second chapter provides historical background to help understand current policies regarding both the regular (peacetime) and the reserve (mobilization) forces of four NATO nations: Denmark, the Federal Republic of Germany, Norway, and the United Kingdom. The chapter also describes these four nations' current manpower policies and practices, ground force structures, and the national and military registration systems.

The final chapter summarizes and draws conclusions.

### WHY STUDY NON-U.S. NATO MANPOWER POLICIES?

Relative to hardware, the manpower dimensions of force structures have been given little analytic attention. Several professional journals deal quite well with weapons and equipment, but no journal deals equally well with manpower issues.

The manpower policies of the North Atlantic Treaty Organization (NATO) countries represent an important factor in the potential effectiveness of NATO forces. But NATO is an alliance lacking supra-national authority. It is composed of sovereign nations, and it is a conglomerate of different systems and philosophies that are reflected in their defense policies.<sup>1</sup> An investigation of present

---

<sup>1</sup>NATO was established under a treaty signed on April 4, 1949 by Belgium, Canada, Denmark, France, Iceland, Italy, Luxembourg, the Netherlands, Norway, Portugal, the United Kingdom, and the United States. Three years later Greece and Turkey joined the Alliance, and the Federal Republic of Germany became a signatory on receiving its sovereignty in 1955.

policies and the underlying conditions as well as the implications of diverse policies may lead to decisions resulting in a more effective NATO force structure.

Pressures on peacetime defense budgets in the face of Warsaw Pact conventional improvements, have led to an increased emphasis in NATO on less expensive reserve forces for rapid augmentation of peacetime forces during mobilization as well as for sustained operations. However, because of a lack of readily available information on the usefulness and time-phased availability of reserve augmentations, these are frequently excluded from military balance assessments and from U.S. reinforcement planning for a European scenario.

There is also talk of improving the efficiency with which NATO's resources are being used. Rationalization, standardization, and interoperability (RSI) are promoted as means to deal with the resource dilemma. However, seldom are these slogans defined in any great detail, and rarely if ever are the implications--if any--of diverse manpower policies and force structures for successful RSI investigated.

Comparative studies of manpower policies, peacetime force structures, and the character and time-phased availability of augmentation or reserve forces are important for several reasons. First, such studies are necessary ingredients in building and maintaining more efficient Alliance force structures as well as in military balance assessments. Second, a useful baseline for negotiating force reductions must include both peacetime strengths as well as the time-phased availability of wartime augmentations. Finally, studies of other nations' policies can generate ideas for alternative policies and yield insight into implementation problems.

Because ground force structures are the main users of manpower and because ground forces vary greatly with respect to manpower procurement and utilization policies, the focus is on manpower dimensions of peacetime and wartime structures.

## THEORETICAL FRAMEWORK FOR ANALYZING MANPOWER POLICIES AND FORCE STRUCTURES

This section identifies and discusses some of the manpower-related choices facing defense decisionmakers. First, the organization of and the relationship between the peacetime and the wartime organization are important issues to be faced. Second, choices exist between procuring only volunteers or a mix of conscripts and volunteers. Third, the trade-off between the number of recruits required to man a force of given size and the length of regular active duty has political, economic and military implications. Fourth, in determining the lengths of regular duty and reserve obligation, the costs and benefits over the entire service life of each individual serviceman warrants examination. Finally, even when policies are implemented to primarily affect the standing, regular forces, the (Total Force) analysis is comprehensive only if it takes into account consequences for both the standing and the reserve component.

### Peacetime and Wartime Organizations

Force structure is defined in this paper as the mix of active and reserve manpower, the allocation of functions among active and reserve manpower, and the way in which conscripts and volunteers fit into the system. Therefore, force structures reflect manpower policies and practices, and differences in manpower policies lead to diverse force structures.<sup>1</sup>

To facilitate the understanding of concepts to be used later in the study, Figure 1 shows four examples of potential force structures and the differences in the relationship between peacetime forces, effective force strength (forces-in-being, standing forces) and the reserve mobilization or augmentation components of a wartime force.

---

<sup>1</sup>Force structure normally includes strategy, tactics, organization and equipment.

# PEACETIME VS WARTIME FORCE

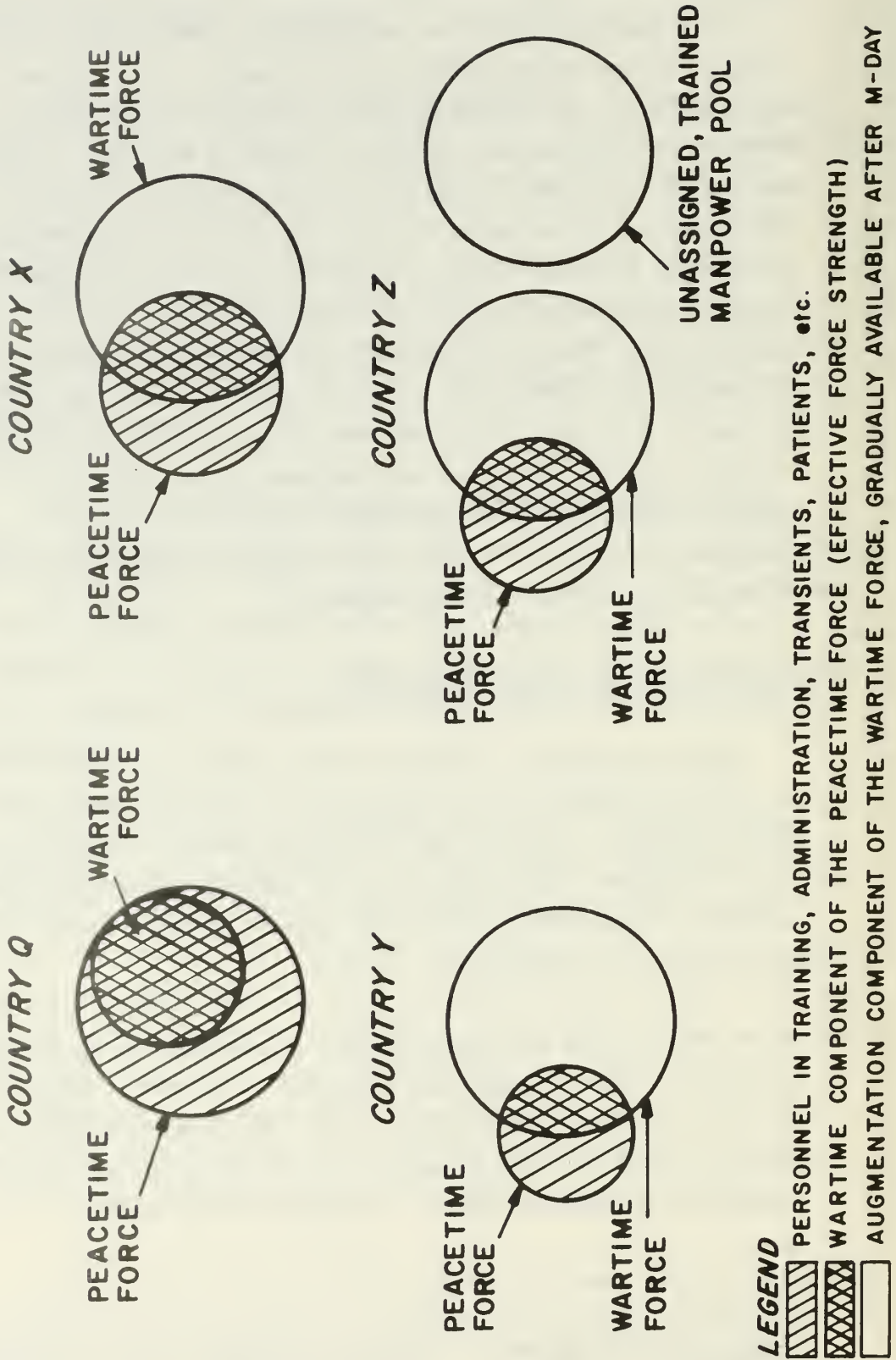

Fig. 1--Hypothetical Total Force Structures

Aggregate peacetime or regular active military manpower includes those in the formal wartime organization (effective force strength) plus individuals in training, patients, prisoners, transients, and those in administrative functions.<sup>1</sup> The first case, Country Q, is an example of a force structure with no reserve augmentation in case of war. Country X exemplifies the case with a relatively small augmentation, and Country Y one with a relatively large wartime augmentation of the peacetime force. Country Z shows the case of a wartime augmentation of the peacetime force, but with a large civilian pool of unassigned, but militarily trained manpower. The wartime component (effective force strength) of the peacetime force, therefore, constitutes only a part of the full peacetime force. Even so, because the numbers are more accessible, most military balance assessments focus on the full peacetime force and generally ignore mobilization augmentations.

Reservists may be organized and trained in peacetime in units that supplement or complement active forces, or they may be used for (1) rapid augmentation by manning peacetime units to full wartime strength or by manning immediately available reserve units, and for (2) sustained operations by providing individual replacements or by manning additional units formed after mobilization.

### Manpower Procurement Alternatives

Various methods can be used for procuring manpower. Fig. 2 suggests one categorization useful for analyzing and choosing among (a mix of) procurement alternatives. Defense manpower consists of both military and civilian manpower, and nations may vary the degree to which defense functions are "civilianized". Military manpower may be procured through a purely voluntary system or through a

---

<sup>1</sup>For now, those in administrative functions are excluded from effective force strength because frequently these are performed by civilians. Later, however, this manpower will be included if assigned as cadre personnel in reserve units.

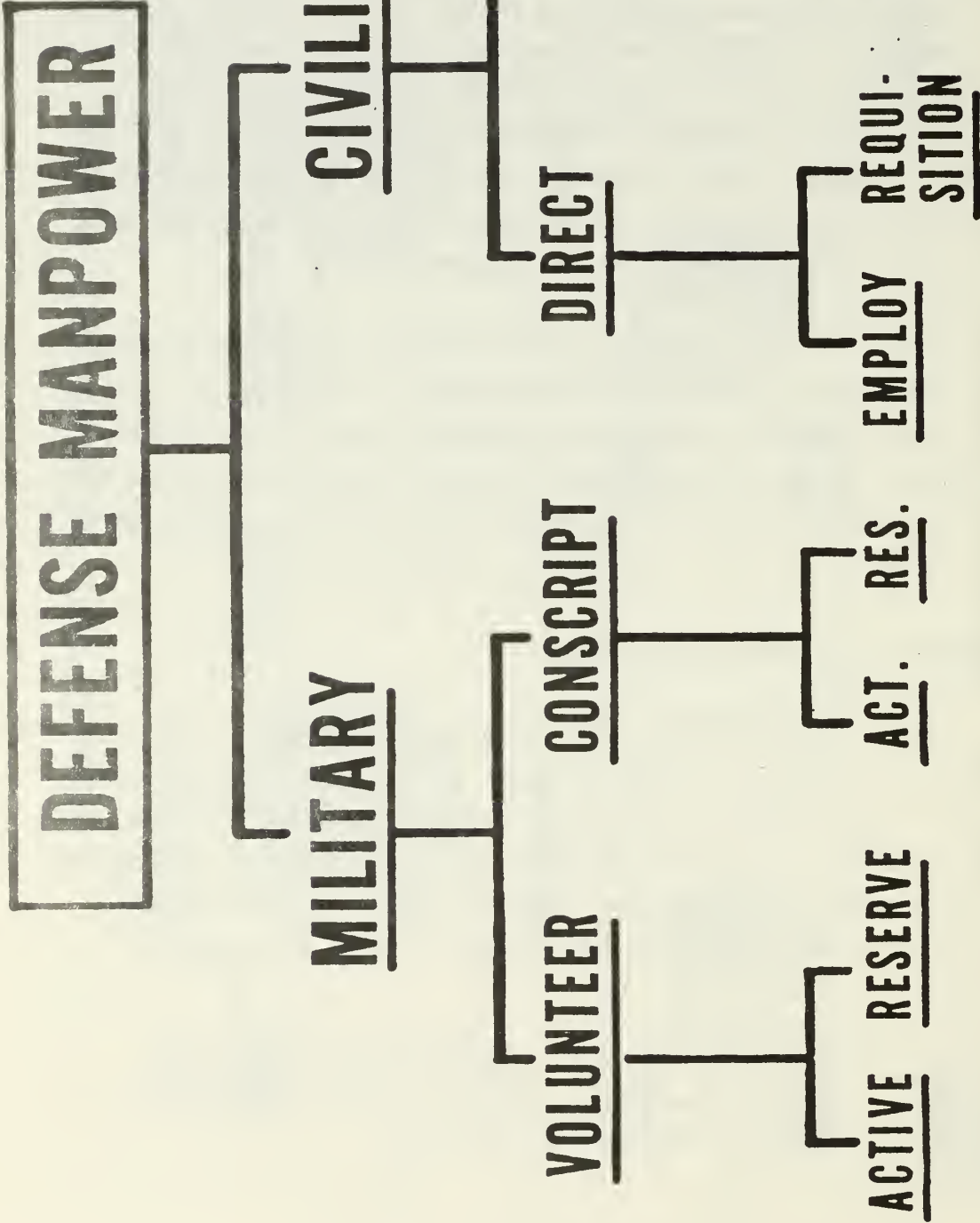

Fig. 2--Alternative defense manpower categories

voluntary system combined with conscription (draft). Furthermore, volunteers and conscripts may be used in both the regular active (or standing) force and the reserve or mobilization force. Civilians may be utilized in the defense sector through direct employment or indirectly under service contracts. Furthermore, given the existence of appropriate legislation, civilians or civilian sector services may be requisitioned in case of emergencies.

Issues related to manpower procurement which must be addressed include (1) the recruitment and retention of volunteers, and (2) the assignment problem associated with universal conscription or alternatively, the selection problem associated with selective conscription, where selection can be performed through exemption and deferment policies, lottery, or by setting strict physical and mental standards.

The most commonly observed arguments for (some degree of) conscription include (1) compulsory service is an essential civic duty; i.e., it is a democratic way of building defense, (2) the resulting high population participation rate in the defense sector integrates the military and civilian sector, (3) only conscription can raise sufficient troops of the desired quality, (4) with current budgetary restrictions, the established strengths cannot be met with volunteers alone, and (5) because many young men choosing to volunteer for extended military duty come from the ranks of conscripts, recruitment of volunteers is aided by conscription.<sup>1</sup>

---

<sup>1</sup>These and the following arguments are dealt with in more detail in Ragnhild Sohlberg, Defense Manpower Policies in Northern and Central European NATO, N-1314-MRAL, The Rand Corporation, February 1980, pp. 5-16.

However, adherence to at least some degree of conscription certainly also has some disadvantages. For example, the training of a large number of conscripts in combat or other standing units has led to decreased readiness of standing forces. Unless conscripts are assigned the same or similar functions during their regular active and reserve duty periods, they must be retrained for the reserve function. Because volunteers and conscripts often belong to the same age group but are accorded different status, rights, standard of living, etc., the personal relationship between them may suffer. In some European nations, significant improvements in conscripts' compensation and conditions of service in the postwar period have diminished the financial justification for maintaining this procurement method.<sup>1</sup> Rarely if ever is universal conscription attained, therefore, the inequity argument is dominant in several nations.<sup>2</sup> It is argued that modern technology and warfare methods require personnel with extensive, and hence, expensive military training. For this training to be cost-effective, trained personnel must serve long terms (to be discussed later).

However, long-term volunteers are not only advantageous. On the average, they will be older, may have higher career expectations and consequently will be dissatisfied with simple, undemanding tasks for prolonged periods, and will be more costly because of higher compensation, more fringe benefits and free time, and because of family obligations. Because of the dislocations and inconveniences associated with frequent moves and unattractive base locations for the family, retention of long-term personnel may require that more consideration is given to deployment and basing than is required for conscripts. Also, a large proportion of long-term volunteers may result in a military elite isolated from society as a whole.

---

<sup>1</sup>Parallel costs have also increased with respect to volunteers while the effective work-time has decreased, resulting in increased cost per effective work-hour for both volunteers and conscripts.

<sup>2</sup>The inequity argument rests on the assumption that universal conscription is more inequitable than selective conscription. This in fact may not always be the case, rather "fair" exemption and deferment policies may increase equity in conscription.



## Trade-off Between Recruits Required and Length of Regular Active Duty

Fig. 3 shows the tradeoff between the number of recruits inducted annually and the length of regular active duty; given force strength or size. The example uses a desired force size of  $10^n$ , where  $n$  is any integer.<sup>1</sup> If the length of regular active duty is fixed at 12 months, then  $10^n$  recruits need be inducted annually. If the length of active duty is reduced to six months; i.e., cut in half, then twice as many recruits ( $2 \times 10^n$ ) need be inducted. On the other hand, if the length of regular active duty is doubled to 24 months, then only half as many recruits ( $.5 \times 10^n$ ) need be inducted annually. This trade-off (or isoquant) curve also shows that as the length of duty increases in equal increments, the incremental savings in annual requirements for new recruits decreases.

Alternatively, if a reduction in force size is planned, for example, from the higher level indicated by A to a point on the curve; i.e., to a force size of  $10^n$ , this reduction can be achieved either by reducing regular duty from 18 to approximately six months (B), by reducing annual accessions (C), or by a combination of reduced accessions and reduced regular duty (as represented by the curve between B and C).

## Cost-Effectiveness of Manpower

Qualitative manpower dimensions, however, are not constant along the trade-off curve. Fig. 4 demonstrates one hypothetical cost-effectiveness time-profile of an individual serviceman. Assuming a typical learning curve, the skill level of this individual increases through basic training and continues to do so

---

<sup>1</sup>For example, if  $n=3$ , the desired force size is  $10^3=1000$ .

**ANNUAL ACCESSIONS ( $10^n$ )**

Annual Accessions (annual number of recruits inducted) <sup>a</sup>	Length of Regular Active Duty (months)	Force Size
$4 \times 10^n$	3	$10^n$
$2 \times 10^n$	6	
$1 \times 10^n$	12	
$.667 \times 10^n$	18	
$.500 \times 10^n$	24	
$.400 \times 10^n$	30	
$.333 \times 10^n$	36	

<sup>a</sup>This table and the associated figure assume:  
 (1) no attrition, (2) inductions are evenly spaced over  
 the year, and (3)  $n = \text{any integer}$ .

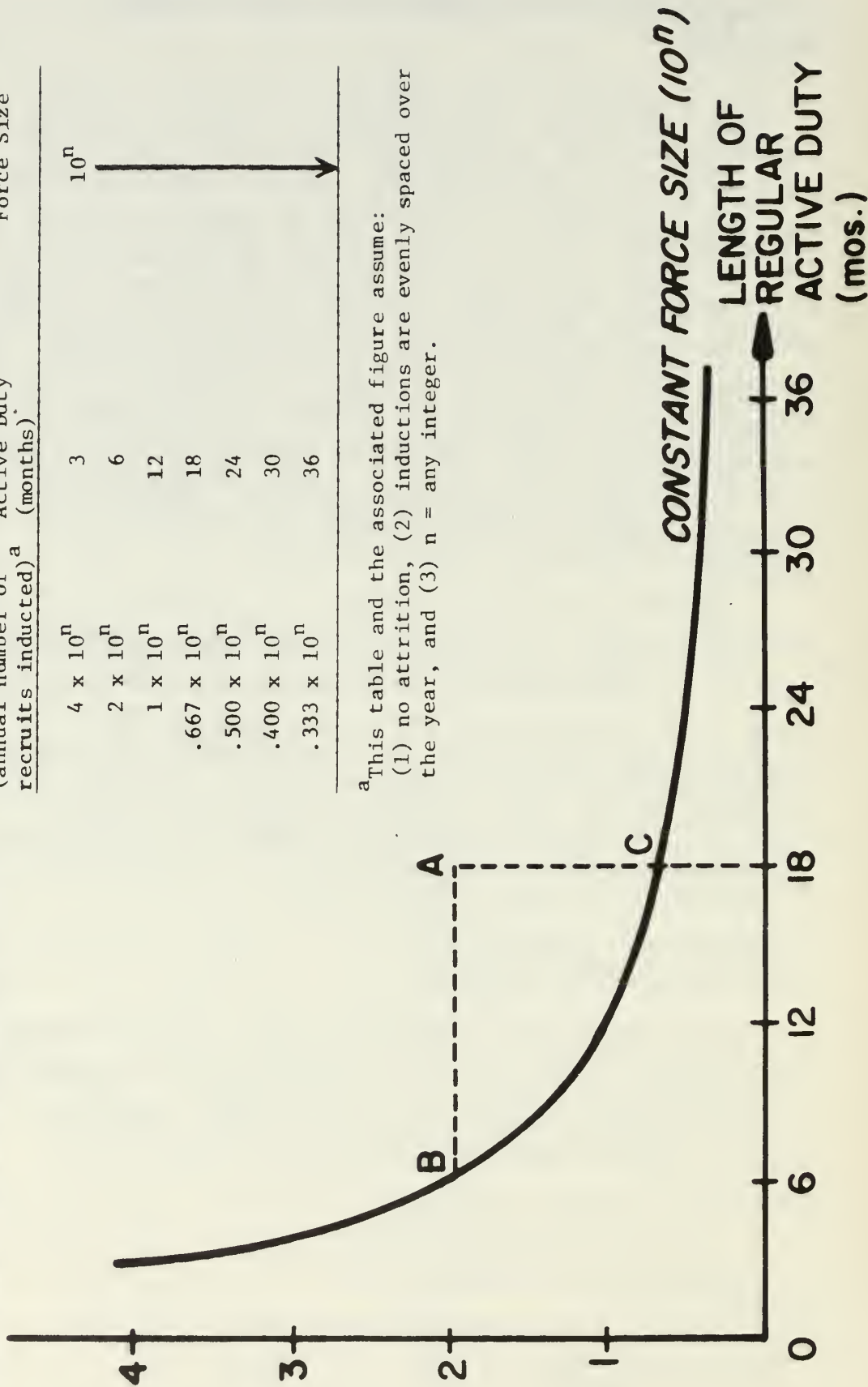

Fig. 3--Tradeoff between length of regular active duty and annual accession requirements (given constant force size)

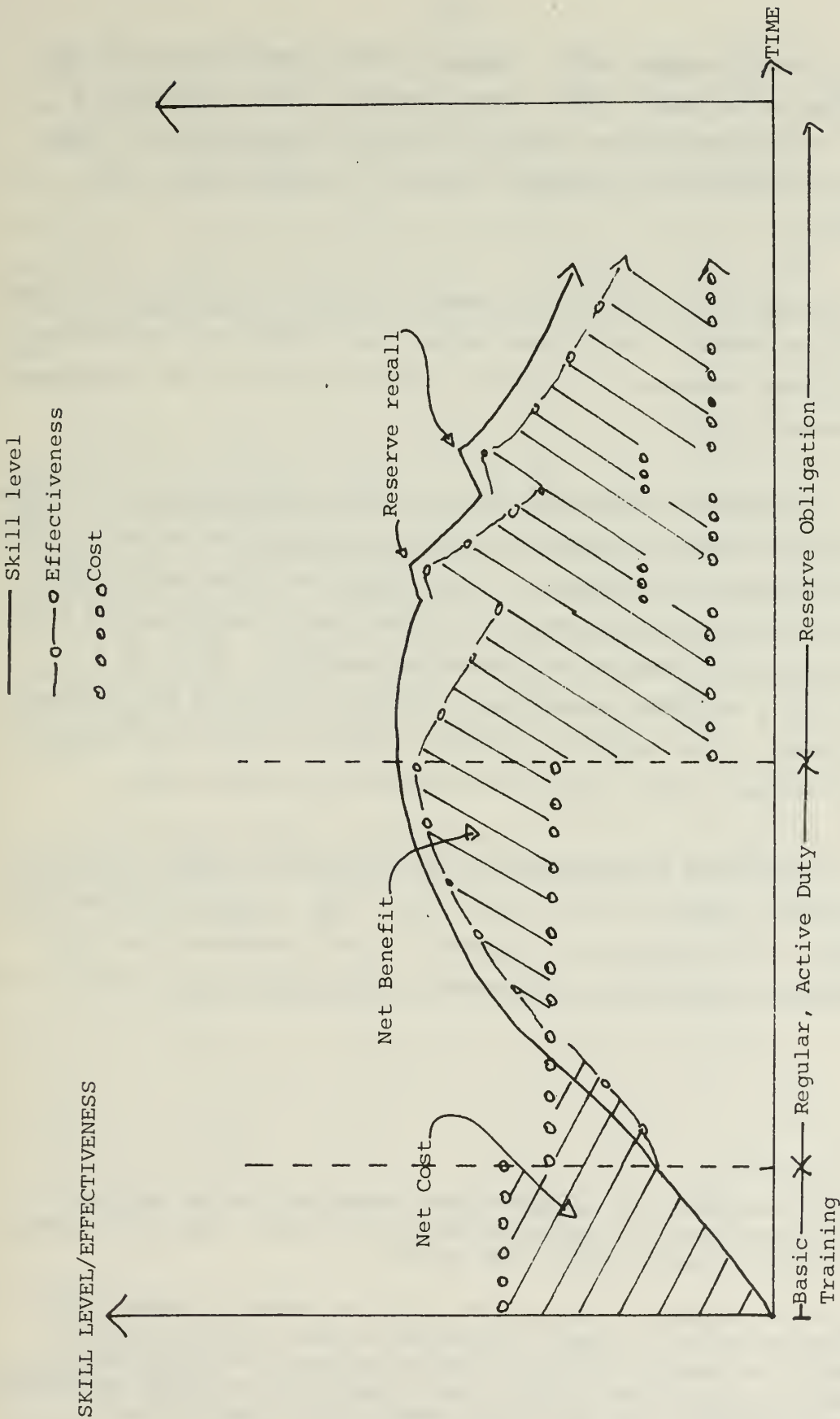

Fig. 4--Hypothetical cost-effectiveness time-profile of a serviceman

during regular active duty. However, after some time-period, the learning curve levels off.<sup>1</sup> Upon discharge, this individual is under reserve obligation, but military skills deteriorate. Upon recall to reserve or refresher training, the skill-level again rises.

The specific location and shape of the skill-level curve depend on the individual's skills and talents upon induction, motivation, quality and relevance of training, the complexity of the functional assignment, etc.<sup>2</sup>

The rapidity with which the skill level deteriorates or becomes irrelevant during the reserve obligation, depends on how well skills are entrenched upon discharge from regular duty, the relationship between military assignment and civilian sector pursuits, the rate of change in military organization and equipment, etc. If a reservist's civilian occupation is closely related to his military assignment, it is certainly possible that the skill level and the effectiveness curves rise after discharge from active duty.

The defense effectiveness of an individual, however, may not correspond directly to the skill level. For a regular active duty soldier, effectiveness also depends on unit readiness (training, equipment) as well as on deployment or deployment capabilities. For

---

<sup>1</sup>If the individual is assigned tasks unrelated to his wartime function or loses motivation or physical fitness, the skill level may actually decline after some point.

<sup>2</sup>It is not suggested that the location and shape of these curves need be estimated. Rather, the model is only intended to help identify and evaluate policies and consequences of alternative policies--focusing on policies which may yield increased net benefit or decreased net cost over the military "life-time" of an individual.

a reservist, effectiveness also depends on the individual's time-phased availability, including the effectiveness of a national or military registration system.<sup>1</sup> Because of child care obligations and pregnancies, on the average, the uncertainties associated with the time-phased availability of female reservists are greater than for male reservists. Consequently, in most military capacities, a woman reservist is not as cost-effective as a man.

The cost curve in Fig. 4 assumes that this individual is a conscript who is rather costly during basic training because of the need for supervision and instructors, unskilled handling of equipment, etc. During regular duty, this hypothetical conscript receives no increase in compensation, requires less supervision, and handles equipment with greater care. Upon discharge to reserve status, costs are limited to administration, record-keeping, storage and maintenance of equipment, etc. and only rise during times of recall.

The specific shape and location of the cost curve depend on the compensation level--for example, whether conscript or volunteer--training requirements, etc.

Fig. 4, therefore, demonstrates that a determination of the cost-effectiveness of an individual must take into account contributions and costs both during regular and reserve duty. At minimum the lengths of regular and reserve duty must be determined so that the benefits perceived as obtained during an individual's military "life-time" at least outweighs the costs. Mobilization and deployment plans, for example, help determine the effectiveness of a reservist.

---

<sup>1</sup>For a discussion of manpower mobilization, ref: Ragnhild Sohlberg, Defense Manpower Policy Analysis: NATO Ground Forces, P-6532, The Rand Corporation, June 1980, Chapter IV.

## Total Force Analysis

Fig. 5 demonstrates the dependence between regular and reserve policies at the force level. This simple example identifies some non-financial consequences of increasing the length of regular active duty.<sup>1</sup> Other policies are unchanged. For example, regular force size, given by the area under the solid or broken line, is held constant.

The solid lines indicate the situation before length of regular active duty is increased. The broken lines indicate the situation after the policy change. As the length of regular active duty is increased, fewer individuals need be recruited annually; the reduction indicated by line a-b. At any one time, fewer individuals are in basic training; indicated by area A. Military effectiveness, or readiness of the standing, regular force, may be measured by the number of individuals with training over and above the earlier maximum level; given by area B.

A comprehensive Total Force analysis, however, weighs not only the consequences for the regular force but also those for the reserve force. It is assumed that before the policy change, a certain proportion of individuals discharged from regular duty enters the reserve force annually; indicated by line 0-c. After the policy change, fewer persons are discharged annually from regular duty, reducing the number available for the reserve component; the reduction measured by line c-d. In a steady state and without compensatory or offsetting reserve policies, the reserve force strength is reduced; indicated by area C.

---

<sup>1</sup>Possible financial consequences include savings in recruitment and basic training costs, or alternatively, a chance to increase effectiveness of recruitment and basic training. Any savings may be offset by the need to increase compensation because of extended duty. For more details on analyzing consequences of changing the length of regular active duty, see Sohlberg (June 1980), Chapter VI.

INTAKE OF MANPOWER FROM  
ONE TIME-PERIOD  
TO ANOTHER

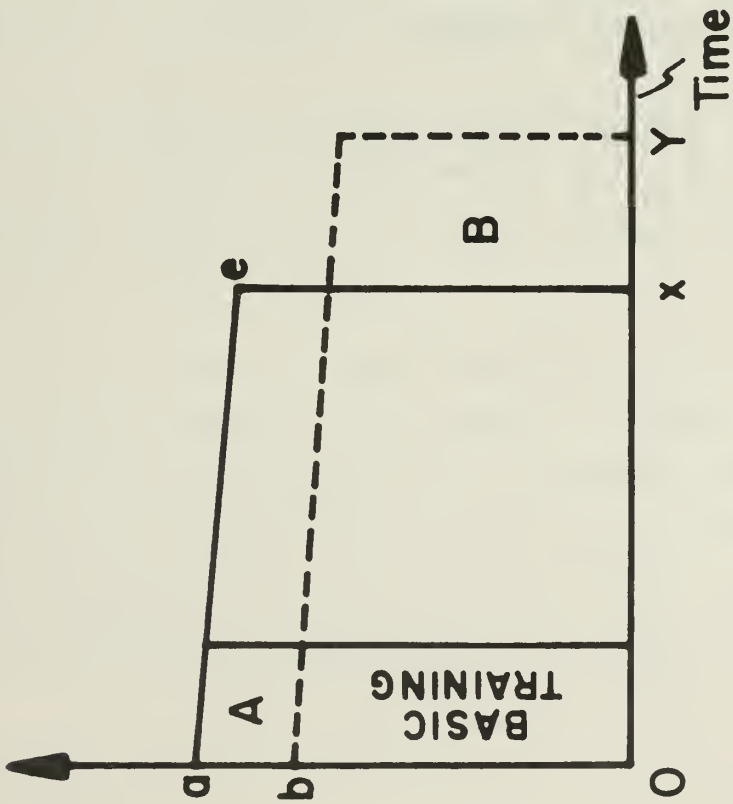

REGULAR, STANDING FORCE

INTAKE OF MANPOWER FROM  
ONE TIME-PERIOD  
TO ANOTHER

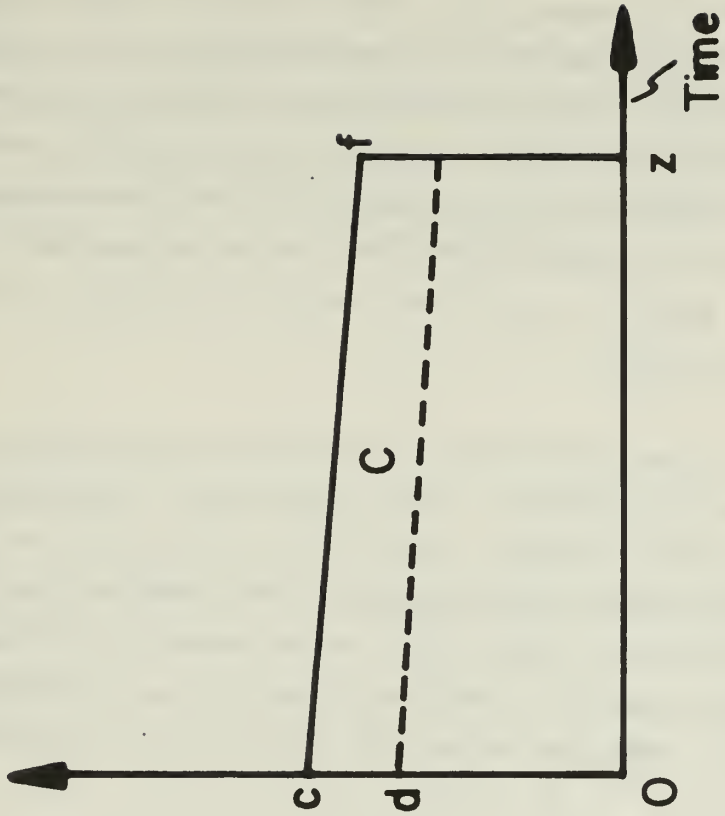

RESERVE FORCE

Fig. 5--Consequences of changing the length of regular active duty  
(Total Force analysis)

This simple model also shows that if, for example, it is desirable to reduce total force size and rather provide remaining units with better training and equipment, this can be achieved by reducing the intake to either the regular or the reserve force. If, for political reasons, it is also desirable to continue to recruit a large proportion of the population, the force reduction can be achieved by only reducing the reserve obligation. This latter change would in itself also result in a younger and possibly better trained force.

Having identified and discussed some choices confronting defense decisionmakers, the next chapter investigates the manpower procurement policies, ground force structures, and national and military registration systems of four NATO nations. Because traditions to a large degree have formed current policies and practices and also constitute constraints on change, a brief historic overview is provided initially for each nation.



## II. NATIONAL SYSTEMS

This chapter provides some historical background to help understand today's manpower procurement policies and describes current policies, ground force structures, and national and military registration systems of four NATO nations: Denmark, the Federal Republic of Germany, Norway, and the United Kingdom.

### DENMARK

#### Background

Conscription in Denmark has traditions back to about 800 A.D. when the Vikings were looting Europe. The country was divided into areas, each obligated to provide one man for the Army. Due to the cost of maintaining a large force, this system was later replaced by one where each great landowner had to provide one fully equipped horseman, and every man had an obligation to serve in person within the national borders in the event of a threat of national disaster.

Up to 1849 conscription was used to various degrees, but in that year universal compulsory national service was introduced with the first democratic constitution. This "basic military law" was reenacted in the Constitution of 1953.

The concept of "universal and equal" national service has generally not applied in Denmark. During the first decades following 1849, the more privileged parts of the people avoided such service. During the period between the two world wars, Denmark had a very limited military potential, so it was not necessary to provide military training to all young men in the relevant age groups. During this period draft by lottery was introduced.

Partly due to Denmark's membership in NATO, all men fit for military service were called up in the period following World War II<sup>1</sup>. About 25 percent were rejected for health reasons. In more recent years it has been possible for conscriptees to substitute military service with civilian compulsory national service. This latter option was selected by about 15 percent of those liable for compulsory service.

### Manpower Procurement Policies

Traditionally, the major manpower procurement policy in Denmark has been conscription. Because force size has always been small relative to the population base, selective rather than universal conscription has been the rule.<sup>2</sup> The Defense Agreement of 1973 also resulted in an organization that did not require calling up everybody fit for military service. One reason given for this change was that the relatively limited employment of regulars, particularly in the Army, meant that in the past, a large part of the budget had been used for training conscripts. Since 1973, while a somewhat higher proportion may be inducted, only about one-third of each male age cohort completes first-term active duty in the military. Selection is done by lottery.<sup>3</sup>

On January 1, 1976 the legal age at which young men make initial contact with the military for classification, was reduced by three months to 19.25 years; i.e., the legal conscription age was

---

<sup>1</sup>In 1971 women were permitted to apply for employment as regular other ranks--in principle under conditions similar to those applicable to male personnel, but with some limitations regarding fields of service and training activity. By June 1975, 420 women were employed in the three services. The Danish System for Employment of Regulars, Denmark: June 1975.

<sup>2</sup>Universality was only approximated immediately following Danish entry into NATO in 1949.

<sup>3</sup>"Dansk Brigad" (Danish Brigade), Arménytt, No. 4, Sweden, 1980, p. 22.

lowered. However, there are opportunities to voluntarily enter the military earlier than at age 19.25.<sup>1</sup>

The defense reorganization in 1973 reduced first term, regular active duty to nine months. Non-commissioned officers (NCOs) have to serve an additional six months, and those who volunteer to serve as reserve officers, an additional nine months.

Figure 6 shows the manpower flows through the Danish ground forces.

Conscripts are trained during their nine months initial military service (18 months for sergeants). In the Army, they are placed in a Training Force which has no explicit wartime function. Here the conscripts are trained to fill less complicated functions in the Augmentation Force or other reserve functions. If assigned to the Augmentation Force after discharge from regular active duty, for up to 18 months they are subject to immediate recall in case of crisis.

After release from the Augmentation Force assignment or directly after regular active duty, a conscript is assigned to regular reserve units in the Field Army Reserve (Other Reserve Units), to the Local Defense Force, or to a Personnel Replacement Depot. The maximum military obligation today is nine years. However, the theoretical obligation lasts until a man is 50 years old. Even after 50 years of age, he is under legal obligation to participate within Total Defense<sup>2</sup> until 55 years old; i.e., in the Home Guard or in Civil Defense.

---

<sup>1</sup>Fakta om forsvar, (Facts about Defense), Defense Command, Press- and Information Service, Vedbaek, January 1978, pp. 28-29.

<sup>2</sup>In the Scandinavian countries Total Defense covers military and non-military defense. Non-military defense includes civil defense, economic preparedness, and psychological defense preparations (mass media, information, etc.).

PEACETIME FORCE ( WITH ADMINISTRATIVE PERSONNEL, ETC., GROUND FORCES' PEACETIME MANPOWER TOTALS APPROXIMATELY 20,000).

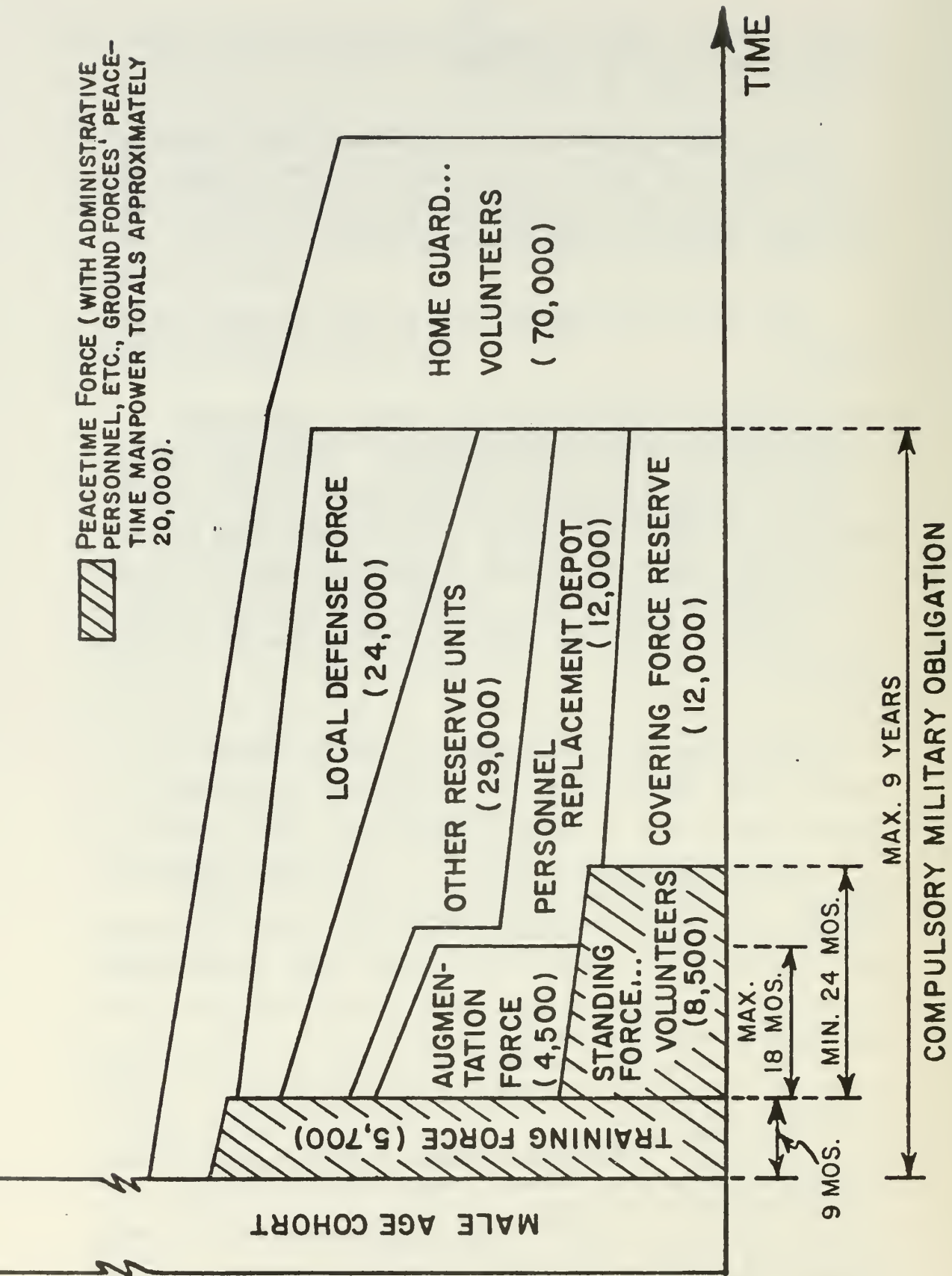

Fig. 6--Manpower flows through the Danish Ground Forces

The all-volunteer (combat-ready) Standing Force recruits only from those who have completed nine months in the Training Force. Those volunteers are obligated for at least 24 additional months of active duty: i.e., a minimum of 33 months.

After serving in the Standing Force, volunteers are still obligated to complete nine years of military obligation. Most volunteers, however, having more military training than conscripts, are assigned to units in the Covering Force Reserve.

Conscripts who have completed their first-term duty, are qualified and encouraged to enlist for voluntary full-time service with one of the units assigned to UN-duty, for further military training during spare time as a member of the Home Guard, or for social activities in a soldier's association. If he enlists for voluntary service, he has the right to obtain civilian education at the expense of the military after completion of 33 months (including the nine months of first-term compulsory service).

If a conscript cannot obtain a civilian job immediately upon dismissal, he has the right to receive some form of unemployment compensation or other assistance.

#### Peacetime and Wartime Ground Force Structure

Because of geographic and demographic characteristics as well as the ease of transportation, the Danish Army has traditionally relied rather heavily on mobilization. This reliance increased somewhat as a result of the 1973 Defense Agreement. The structure which has been implemented since then, is shown in Table 1.<sup>1</sup>

---

<sup>1</sup>Chief of Defense, Handout on the Danish Armed Forces, (various years), and information obtained during visits to Danish Defense Command, Vedbaek, March 1978.

DENMARK'S ARMY WARTIME FORCE STRUCTURE<sup>a</sup>

Army Wartime Force (78,000)		Mobilization Force (55,000)	
Covering Force (13,000)			
5 Armoured Infantry Brigades and other units (25,000)		Other smaller units (53,000)	
Standing Force (8,500)	Augmentation Force (4,500)	Field Army Reserve Force (41,000)	Local Defense Force (24,000)
Partly or fully manned high priority weapons and units	Mainly support unit	Covering Force Reserve (12,000)	Other Reserve Units (29,000)
All-volunteer	Mainly conscripts discharged after 9 mos. in the Training Force	7,000 in "temporary security force", 34,000 in lower priority units	Ex-service conscripts and volunteers not required in the Field Army Reserve Force
		Some discharged from Standing Force or Training Force, others transferred from Augmentation Force	Mainly transferred from Augmentation Force or Covering Force Reserve
		Mainly engineer, transportation, and supply units	Mainly support units
		Alarm recalls, no regular refresher training	Refresher training up to a total of 40,000 man-days per year
Min. 33 mos. regular, active duty		Max. 18 mos. in this reserve status	On the average eight years in this status
Readiness:		M-day	Max. nine years
		M+1 day	No later than M+3 days

<sup>a</sup>The Ground Forces also include the Personnel Replacement Depot (12,000) and most of the Home Guard (70,000), and 50,000 men with special reporting orders in case of emergency.

The Army Wartime Force, comprising the Covering Force and the Mobilization Force, is structured around five armoured infantry brigades. Three of the brigades belong to the Jutland command and two to Zealand. Due to variations in their standing forces, the brigades differ slightly in organization. The typical armoured infantry brigade structure is shown in Fig. 7.

None of the brigades is fully manned in peacetime. Rather, the Standing Force of 8500 professional soldiers man key positions, units, and weapons. Only immediate defense tasks can be undertaken by this force alone. In case of crisis, units from the Augmentation Force (4500 men) are expected to be in place within 24 hours. Recall of manpower in the Augmentation Force does not require a regular mobilization order. After consultation with the Minister of Defense, the Chief of Army can recall these reservists.<sup>1</sup> The augmentation units provide some immediate support to the Standing Force. The Standing Force plus the Augmentation Force form the Covering Force.

Subsequently, combat and support units and individuals from the Covering Force Reserve are called up. These 12,000 men bring standing units to their full wartime strength and full operations at the brigade level can take place.

Finally, other reserve support units will be called up. This system of phased call-up is related to the priority of tasks involved. The whole mobilization process is expected to be completed within M + 3 days.

To ensure full manning in the event of mobilization, each reserve unit is authorized at a manning level of 10 percent above the Table of Organization<sup>2</sup>. If some personnel are not immediately

---

<sup>1</sup>"Dansk Brigad," Arménytt, nr. 4, 1980, pp. 18-22.

<sup>2</sup>The Table of Organization (and equipment) sets out the authorized numbers of men and major equipment in a unit/ formation.

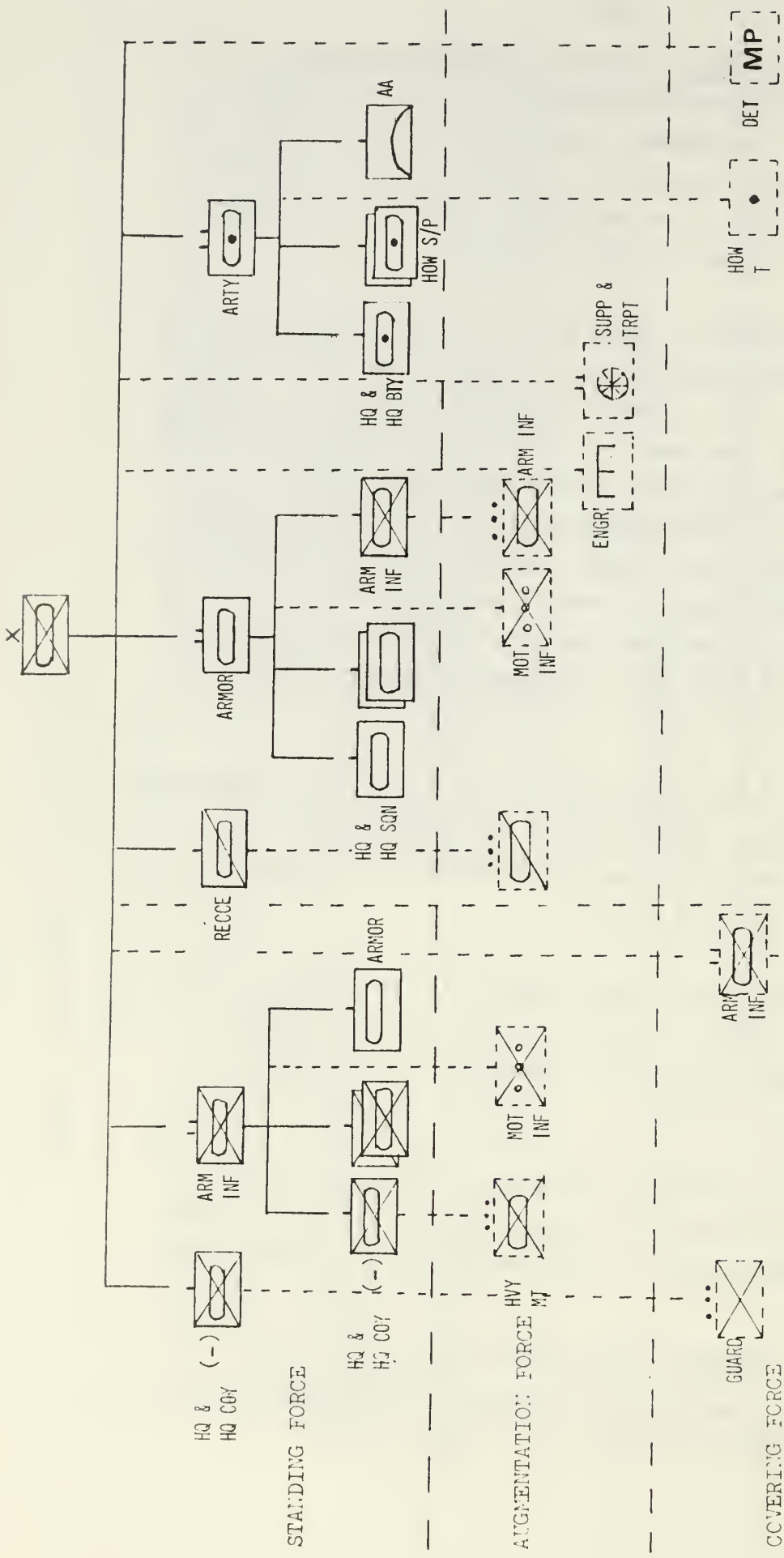

Source: Chief of Defense, Handout on the Danish Armed Forces, May 1975, Annex 4.

Fig. 7--The Danish armored infantry brigade



available at mobilization, each unit recalls 10 percent more manpower than is required to reach wartime strength. Surprise (alarm) call-ups have resulted in close to 100-percent manning levels. The Field Army draws some of its cadre personnel and support elements from among the 7250 men in administrative units, schools, etc.

About 7000 men in the Field Army Reserve Force of 41,000 men are assigned to a "temporary security force."<sup>1</sup> This force is organized into high priority reserve units in the Covering Force Reserve, and the members are provided with a special call-up order in case of mobilization. The remainder, about 34,000 men, are formed into lower priority units. When all these units are in place, sustained operations can be conducted.

The Mobilization Force consists of the Field Army Reserve Force and the Local Defense Force. Regional Defense comprises the Local Defense Force and the Home Guard. In peacetime, the Local Defense Force consists of seven regional staffs and a few units necessary to ensure a rapid and effective mobilization of local defense units. The Home Guard, consisting of both men and women, maintain personal equipment, weapons, and ammunition at home. Consequently, they can be rapidly mobilized<sup>2</sup>.

Of the 78,000 men in the Army Wartime Force, about 10,000 are not fully equipped with modern battle uniforms. These men belong to the lowest priority units, mainly in the Local Defense Force.

Of the roughly 200 tanks in the Wartime Force, about 160 are fully manned in peacetime. The Standing Force is therefore able to provide initial defense against limited but concentrated attacks on Danish territory.

---

<sup>1</sup>Foreløpig sikringsstyrke.

<sup>2</sup>Defense Command, Dansk Forsvar af i dag (Danish Defense of Today), Vedbaek, October 1977, pp. 27-28.

Each Field Army brigade is composed of individuals and units from (1) the Standing Force--headquarter units, one infantry battalion located on the island of Bornholm<sup>1</sup>, a reconnaissance squadron, armoured battalions, artillery battalions--most units which are not fully manned in peacetime, (2) the Augmentation Force--infantry companies, engineer companies, service support units, (3) the Covering Force Reserve--armoured infantry and artillery battalions, and (4) Other Reserve Units--mainly combat and logistics support.

The 1973 reorganization of the Danish Army has some limitations. The Training Force has at least in the past had a shortage of cadre personnel and officers which delayed the buildup of the number and composition of units as announced in 1973. The problem was alleviated by the 1977 Agreement when the Minister of Defense was given the authority to adjust the relative sizes of personnel categories for example as required by technological developments.<sup>2</sup> However, because conscripts in the Training Force are not planned for use at mobilization, the units can devote themselves exclusively to training the men for their assignments in the Augmentation or the Mobilization Force. Consequently, the units in the Training Force do reach a skill level seen as "acceptable" with regard to expected wartime tasks.

Even so, limited training takes place at the brigade level. Each of the five brigades participates in two large scale exercises every year, one with the brigade somewhat reduced. These exercises last up to 14 days. Such exercises incorporate units and individuals from the Standing, Training, and Mobilization Forces. Except for the months of July and August, brigade exercises take place every month of the year.<sup>3</sup>

---

<sup>1</sup>Bornholm is a Danish island in the Baltic Sea.

<sup>2</sup>Minister of Defense, Bilag 2 til Forsvarsministerens skrivelse af 15. marts 1977, Copenhagen, March 15, 1977.

<sup>3</sup>"Dansk Brigad," Arménytt, No. 4, 1980, p. 22.

The Field Army's budget is also insufficient for recalling enough reservists for refresher training, exercises, and mobilization exercises. Before 1977, the annual man-day budget for recalling reservists was only 30,000. In 1977 it was increased to 40,000. Even so, this level only permits recall of high-priority units, some retraining of individuals in the Mobilization Force, and a surprise (maximum) four-day call-up of individuals assigned to the Augmentation Force.

The increased budget allows 32,000 man-days for recalling men in the Mobilization Force. 245,000 man-days would be required to recall 35,000 men for seven days annually or for two weeks biannually.<sup>1</sup> (The Mobilization Force consists of approximately 350 units of company size, each with 100 men.)

Regardless of spending levels, the Army in particular will be in the market for new equipment over the coming years; e.g., armoured anti-tank vehicles and additional Leopard tanks. Two new helicopter units are also planned for the army air arm (Haerens Flyvetjeneste).<sup>2</sup>

The Danish Home Guard is based solely on volunteerism. Most members have no prior military service. The members sign one-year contracts subject to termination at three months' notice. Those who have not completed military service are obligated to 100 hours of basic training the first year and 50 hours of advanced training annually during the second and third years. Thereafter, a member is under obligation to serve only 24 hours per year.

---

<sup>1</sup>About 8000 man-days are used for four alarm recalls of selected units in the Augmentation Force each year; i.e., approximately 500 men are called up for four days, four times a year. The remainder of the man-day budget is allocated among high-priority units in the Mobilization Force.

<sup>2</sup>"Danish Armed Forces Plan for the 1980s," International Defense Review, no. 2, 1980, p. 167.

## Registration System<sup>1</sup>

All Danish residents are provided with a "person-number" upon birth. This number remains unchanged throughout life. All residents are under legal obligation to report any change in residence--whether within the country or whether the individual leaves Denmark--to local, civilian authorities (Folkeregister). If moving within the country, each individual is required to report to the Folkeregister in the area where he or she takes up a new residence.

In 1968, a Centralized Personal Registration (CPR) system went into effect. This is a form of data-collecting system using computerized data processing. The register amasses information on each resident including some data previously obtained from the census.<sup>2</sup> At the time of writing, it is not known whether the military has access to this system for purposes of tracing an individual's place of residence.

When recalled for training, a reservist does not have to report to the Folkeregister unless he gives up his residence. In other words, a temporary absence from home because of short recalls does not have to be reported. However, when an individual is called up for initial, regular active duty, the temporary but extended change of residence must be reported.

Whether he takes up his old residence or moves to a new one, it is the responsibility of the individual to report his discharge and civilian address to the Folkeregister within five days of discharge from regular active duty. If he has been given a reserve assignment, he is also expected to report any address change to his regiment/air station either by phone or in writing.

---

<sup>1</sup>Unless otherwise noted, the major source for this section is Chief of Army, Grundbog for Menige (Information for privates), No. 7, Denmark, 1976, Secs. 1.3, 2.9

<sup>2</sup>Facts about Denmark, Politikens Forlag, Copenhagen, 1972, p. 3.

All contacts with the military after discharge from regular active duty must go through the personnel office of the individual's regiment/air station. All reservists are also provided with a "soldier book" (soldaterbogen/orlogsbogen) containing all the information an individual may need for reporting for reserve recall or upon mobilization. The individual's military identification tag is also inside the cover of this book.

## THE FEDERAL REPUBLIC OF GERMANY

### Background

The deep-rooted Prussian military tradition was shattered by the defeat of Germany in World War II, the dissolution of the Third German Reich, the dismemberment of the German state, and the demilitarization that followed. Today "tradition in the Bundeswehr (Bw; the German Armed Forces) cannot be anything except what is justified under the Constitution. The Basic Law is the touchstone."<sup>1</sup>

In contrast to the other countries under discussion, the Constitution or Basic Law of 1949 had to be amended to allow for the development of a military. Since conscription was linked to the establishment of a relatively large armed force, many were opposed to this idea. The main reason given for this attitude was that rearmament would hinder reunification of the two Germanies.

The suppression of the Hungarian revolt in 1956 by Soviet troops improved support of the government's rearmament policy. In that year, three important laws were passed: (1) The Soldier's Act (Soldatengesetz) which guaranteed full civil rights to the troops, (2) The National Military Service Act (Das Wehrpflichtgesetz) which

---

<sup>1</sup>White Paper 1979, Bonn, September 4, 1979, Sec. 259.

was originally presented in May 1955 and finally passed after long and heated debate, and (3) laws regulating the term of military service.

In the beginning, personnel for the armed forces were procured by recruiting volunteers for three-year terms in the Army (four years in the Air Force and Navy). In addition, 10,000 men were drafted each quarter, initially for a period of 12 months in the Army or the Air Force. By the end of 1956, a total of 120,000 men were in uniform. In August 1961, the same month the Berlin Wall was erected, the term of obligatory service was increased to 18 months.

The Bundeswehr (Bw) was created in an environment where the general population was not favorable to people in uniform. The slogan among many young Germans was "Ohne mich" (without me). The new Army had to represent a clear break with the past, win the confidence of the German people, and establish the proper relationship between soldiers and their military superiors because the traditional "iron discipline" was inconsistent with the newly proclaimed status of the "citizen in uniform".

The concept used to promote these goals was initially called Innere Gefüge (internal structure) later changed to Innere Führung (leadership and civic education). "Innere Führung has its roots in the Constitution and in military law. It embraces the basic concept underlying the relations between the armed forces, the State, and society at large, and it also included the guidelines and rules of behavior governing relations between superiors and subordinates.... The idea of the 'citizen in uniform' holds incontestable sway in the Bundeswehr." Orientation about Innere Führung is given to commanders, general staff officers, and officers and NCOs. The school providing such training is also responsible for public information work and for fostering contact with the armed forces of other countries.<sup>1</sup>

---

<sup>1</sup>White Paper 1979, Bonn, September 4, 1979, Secs. 244-245.

General unrest and dissatisfaction with society as a whole started to spread in 1967.<sup>1</sup> The height of student unrest occurred in 1969 but culminated in 1972-73. This dissatisfaction also affected the Bw, focusing on (1) inequity in conscription because increasing age cohorts decreased universality, (2) recruitment problems in the officer corps, and (3) the training burden resulting from conscription of a large proportion of each age cohort.

The equity problem associated with compulsory military service had become so pronounced by the early 1970s that a special commission was established to investigate the problem and to explore alternative ways to achieve greater equity.<sup>2</sup> Its first report, Equity in Conscription in the Federal Republic of Germany, was presented in 1971. The Commission noted that the number of men liable for military service would increase relative to manpower requirements, and hence, equity in conscription could not be achieved. Furthermore, the target ratio of volunteers to conscripts was unlikely to be met in the future due to social conditions and the situation in the labor market.

The Commission recommended policies to ameliorate the inequities in conscription without moving to an all-volunteer force. In line with these recommendations, then Minister of Defense, Helmut Schmidt proposed in 1971 to raise the Bw strength to 500,000 from that level at which it was frozen in 1967 (460,000). This recommendation was less for reasons of combat effectiveness than for social justice. He also suggested that the length of regular active duty be reduced from 18 to 15 months and that military pay to volunteers at all levels be made equivalent to that given to civilian counterparts. In 1972 the length of regular active duty was reduced to its current level of 15 months.

---

<sup>1</sup>White Paper 1975/76, Bonn, January 20, 1976, Sec. 283.

<sup>2</sup>The Force Structure Commission of the Government of the Federal Republic of Germany.

The Force Structure Commission was also tasked with developing a new force structure for the end of the 1970's. The Commission's second report in 1972 recommended a reorganization of the Army from 33 to 36 brigades.<sup>1</sup>

### Manpower Procurement Policies<sup>2</sup>

Compulsory military service now involves 15 months of regular active duty. Of the overall personnel strength of the armed services (495,000), conscripts constitute less than 50 percent and a little over 50 percent in the Army. The manpower flows through the West German ground forces are shown in Fig. 8.

Males are eligible for conscription upon reaching age 18. In 1975, the average age of a conscript upon induction was 20.1 years, and the average time between school-leaving and entering military service was four years and four months. Consequently, upon induction most conscripts hold final certificates of vocational training. In 1975, only ten percent (including school, college, and university students) had no vocational certificate. Even so, conscripts are generally trained for less complex tasks because the rapid technological development of military equipment has increased the need for long-term personnel. To fill positions requiring more specialized training, the Bw now uses what is called "term-personnel" (Soldat auf Zeit)<sup>3</sup>. Approximately 58 percent of each age cohort complete regular active duty in the military.<sup>4</sup>

---

<sup>1</sup>The Force Structure in the Federal Republic of Germany: Analysis and Options.

<sup>2</sup>White Paper 1979, op.cit., Secs. 272, 289-294.

<sup>3</sup>Conscripts with 15 months service may fill positions up to and including lower grade corporal (Unteroffizier). Only those with minimum two years service (Soldat auf Zeit) fill positions from higher grade corporal (Stabsunteroffizier), sergeant (Feldwebel), and up.

<sup>4</sup>Letter and comments on earlier version of manuscript from OTL i.G. Gerhard Ludwig, Ministry of Defense (Fu S IV 2), Bonn, 12 December 1980.



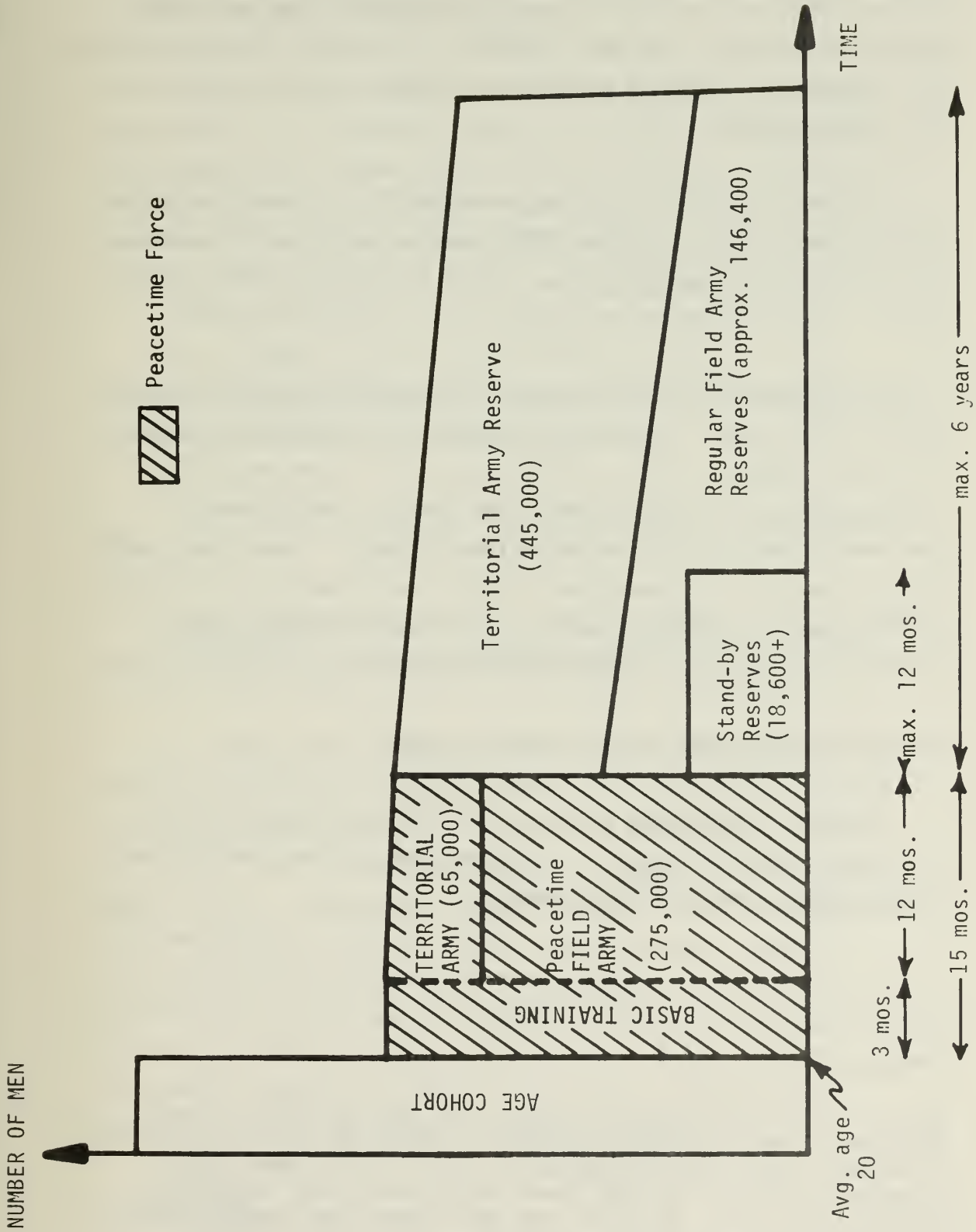

Fig. 8--Manpower flows through the West German Army (Field Army and Territorial Army)

From 1976 to 1979, the margin between effective and authorized strengths has narrowed, and the manpower situation is balanced so far as regular servicemen are concerned. A shortage of short-service volunteers on 3 to 12 year contracts (8.7 percent under authorized strength) has been offset by utilizing civilian personnel and conscripts. There is a surplus of short-service volunteers on two year contracts.

The annual surplus of young men eligible for induction will increase until 1983, but from 1988 onward a deficit will develop. Consequently, the Bundeswehr has looked for ways to offset this deficit, one of which is an expanded use of women volunteers.

At the beginning of each quarter, approximately 44,000 men are called up for basic training in the Army (the Field Army and the Territorial Army). Their service begins with three months in training units. Following this, they receive twelve months' post-basic training with an operational element. About one fourth of the conscripts in operational Field Army formations is replaced each quarter with fresh personnel. Civilian personnel number 180,000 or 27 percent of total defense manpower.<sup>1</sup>

### Peacetime and Wartime Ground Force Structure<sup>2</sup>

The West German Army consists of the Field Army, which is transferred to NATO command in wartime, and the Territorial Army, which remains under national command.

---

<sup>1</sup>Ibid, Sec 311.

<sup>2</sup>Major sources: (1) Die neue Struktur des Heeres, Press release, Ministry of Defense, Bonn, November 7, 1978, (2) Interviews, Ministry of Defense, Joint Staff/Organization (FÜ S IV 2), Bonn, 22-23 September 1980, (3) "Ny västtyska armeorganisation," Arménytt, Sweden, March 1979, pp.16-18, and (4) Letters and comments from OTL i.G. Gerhard Ludwig, Ministry of Defense (FÜ S IV 2), Bonn, November 1978 through December 1980.

On November 6, 1979--as a result of approximately six years of analysis and experimentation--the West Germans decided to adopt a new Army structure called Heeresmodell 4 (Army Structure 4). Table 2 provides an overview of the organization, the readiness, and the strength of the new German Army.

The basic organization above the brigade level will be maintained; i.e. the three corps and the 12 divisions from Heeresmodell 3. Eleven of the twelve divisions are distributed among the three corps, while the 6th armoured infantry division in Schleswig-Holstein, together with Danish units, is assigned to the NATO command covering the Baltic approaches (BALTAP).

The airborne division has a particular status in that its three brigades are divided among the three corps and has a peacetime staff primarily responsible for unified training.

It is expected that the reorganization will be completed by mid-1980's.

Field Army: The Field Army can be described at three organizational levels: Corps, division, and brigade.

(1) Each corps staff can command up to five divisions. In addition, two basic unit types outside the divisional structure are assigned to each corps and are under the command of the corps commander at all times; Korpsverfdgungstruppen and Korpsversorgungstruppen. The Korpsverfdgungstruppen include reconnaissance, and communication units as well as combat support units like artillery and air-defense. In Heeresmodell 4 each corps will also be assigned an anti-tank helicopter regiment, each equipped with 56 helicopters. The air-defense battalions will be reorganized into air defense regiments equipped with missiles (ROLAND II).

Table 2

## THE FEDERAL REPUBLIC OF GERMANY:

## ARMY STRUCTURE 4

## THE GERMAN ARMY:

- I. FIELD ARMY
- II. TERRITORIAL ARMY

I: FIELD ARMYOrganization:

3 corps with combat- and support units  
 12 divisions with combat- and support units, of which:  
   11 divisions are distributed among the 3 corps, and  
   1 division (6th armoured infantry division in Schleswig-  
   Holstein) is assigned to BALTAP  
 36 brigades, of which:  
   17 armoured (Panzer)  
   15 armoured infantry (Panzergrenadier)  
   1 light infantry mountain (Gebirgsjäger)  
   3 airborne (Luftlande)

## In addition:

Operational- and training units (Einsatz- und Ausbildungs-  
Einheiten) where new enlistees and conscripts are placed  
 initially for six weeks to three months.

## Upon mobilization, there are:

Replacement battalions (Wehrleit/Ersatzbattalione) where  
 approximately 50 percent of the reservists are assigned.  
 Here they are brought to the division or brigade level  
 where they are kept in Field Replacement battalions  
 (Feldersatzbattalione) until needed for replacement.

Readiness:

The 36 brigades are manned at 90 percent in peacetime,  
 corresponding to NATO's highest readiness category, A 1.  
 Men with less than three months training will be replaced by  
 trained reservists in stand-by readiness.

Strength:

Peacetime.....275,000  
Mobilizable.....165,000  
 Total wartime.....440,000

(continued)

Table 2, continuedII: TERRITORIAL ARMYOrganization:

- 3 Territorial commands: North, South, and Schleswig-Holstein
- 5 Local defense districts (Wehrbereichskommandos, WBK)
- 28 Local defense regions (Verteidigungsbezirkkommandos, VBK)
- 78 Subdivisions of local defense regions (Verteidigungskreis-  
kommandos, VKK)
- 27 brigade-equivalents, of which:
  - 6 Home Defense Brigades (Heimatschutzbrigaden) similar to armoured infantry brigades
  - 6 Heavy Home Defense Brigades (Heimatschutzbrigaden/equipment holding units) similar to armoured infantry brigades
  - 15 Home Defense Regiments (Heimatschutzregimenter) formed into 45 light infantry battalions
- 150 security companies
- 300 security platoons

Readiness:

- 6 Heimatschutzbrigaden, of which:
  - 4 at 65 percent strength in peacetime and
  - 1 at 52 percent,
  - 1 at 85 percent,
 corresponding to NATO's readiness level B 1. Remainder is mainly equipment-holding units. Some may require post-mobilization training, however, most are mobilizable within M + 3 days.

Strength:

Peacetime.....65,000

Mobilizable.....445,000

Total Wartime.....510,000

---

WARTIME POTENTIAL OF THE GERMAN ARMY: close to 950,000, of which approximately 65 percent is mobilizable.

(Total wartime potential of the Bundeswehr is approximately 1,250,000)

(2) With the exception of the airborne, all divisions in the new model will include one air-defense regiment each equipped with armoured anti-aircraft vehicles (36 GEPARDS). The 6th division in Schleswig-Holstein, which is not assigned to one of the corps commands and therefore cannot be supported by the corps' anti-tank helicopter regiments, will be provided with its own anti-tank helicopter battalion. The divisions' armoured reconnaissance battalions will also receive better equipment.

(3) The number of brigades will be increased from 33 to 36. Two armoured infantry brigades will be upgraded to armoured brigades, and the existing (light infantry) Jägerbrigade and one Gebirgsjägerbrigade will be upgraded to armoured infantry brigades. Only one Gebirgsjäger-brigade will remain.<sup>1</sup>

In the original Heeresmodell 4 each brigade was supposed to consist of four armoured or armoured infantry brigades rather than the three in Heeresmodell 3. However, because of the investment expenditures required to implement this reorganization, two alternatives were explored: (1) retain the three-battalion structure, and (2) maintain three standing (präsente) battalions and one cadre- or reserve/mobilization battalion.

The result was a compromise. As shown in Figure 9, in peacetime each brigade will consist of three battalions, each with four companies as well as expanded (+) staffs and support. In wartime, each brigade will consist of four battalions, each with three combat companies. The fourth battalion will be created by transferring one company from each of the three peacetime battalions as well as personnel from the expanded peacetime staffs and support companies.

---

<sup>1</sup>Originally it was intended to transform all lightly equipped units to armoured infantry units. However, at a later time it was decided that it was still necessary to maintain units trained in mountain combat. Because of insufficient exercise areas in the mountains and because of resistance on the part of the local population, however, it was impossible to train with heavy, mechanized units.

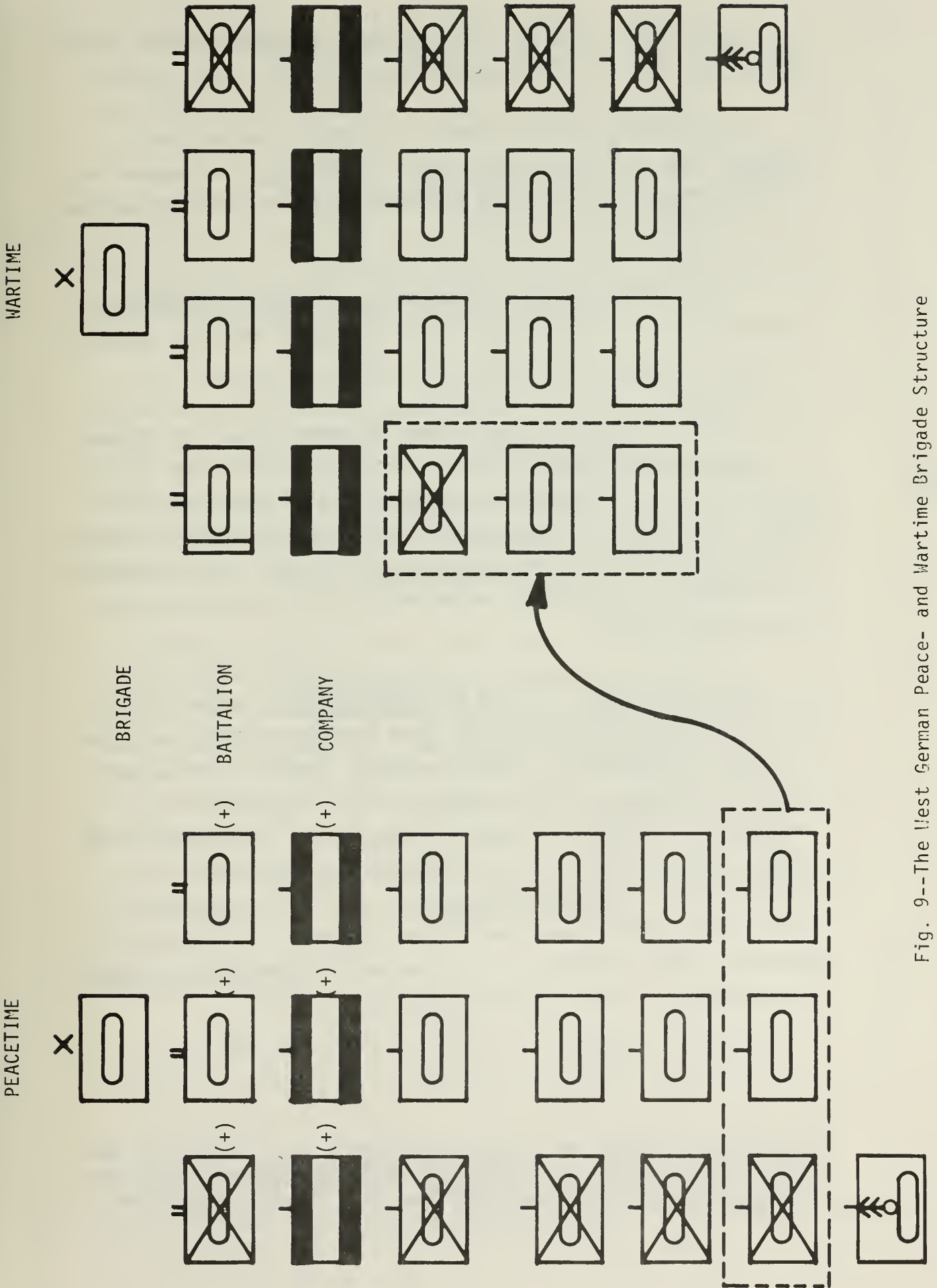

Fig. 9--The West German Peacetime and Wartime Brigade Structure

The airborne brigades will already in peacetime consist of four battalions each with three companies.

When changing from the peace- to wartime organization, manpower with less than three months training will be replaced by trained reservist. Peacetime exercises take place with the wartime organization.

In peacetime, the 36 brigades will be manned at 90 percent of wartime levels; corresponding to NATO's highest readiness category of "A 1".

A special reserve status is held by approximately 18,600 men in Verfügungsbereitschaft (stand-by reserves). These men who are in this status for maximum 12 months after discharge from active duty, are formed into fully equipped active units or will be used to replace men with less than three months training. The number will be increased from 18,600 to approximately 40,000 within the next three to four years.

Territorial Army: In the new Heeresmodell 4, shown in Fig. 10, the six Heimatschutzbrigaden (Home Defense Brigades) which up till now corresponded to lightly equipped infantry brigades and only were assigned rear area defense tasks, are upgraded to correspond to armoured infantry brigades and will be equipped with tanks. Their mission will be to support Field Army units in forward defense (Vorneverteidigung) as well as to perform the earlier rear area defense tasks. Four brigades will be manned in peacetime at 65 percent, one at 52 percent, and one at 85 percent, corresponding to NATO readiness category "B 1".<sup>1</sup>

---

<sup>1</sup>When Heeresmodell 4 was adopted in November 1979, six of the 12 Heimatschutzbrigaden were named Heimatschutzkommandos and six were named Schwere Heimatschutzregimenter. However, at a later time they were renamed.



The six Heimatschutzbrigaden will remain mainly as equipment holding units. However, their equipment will be upgraded and the units will also correspond to armoured infantry brigades.

Even the local defense Sicherungstruppen will be reorganized. Instead of the 27 partly motorized Sicherungsbattalionen in Heeresmodell 3, there will be 45 completely motorized Heimatschutzbattalionen (Home Defense battalions) organized into 15 Heimatschutzregimenter (Home Defense regiments).

The 150 completely motorized Heimatschutzkompanien (Home Defense companies) are assigned defense of civilian targets which may be of interest to the military (Objektschutz).

The number of Sicherungszügen (platoons), tasked with defending depots, airfields, etc., will be increased from 120 to 300. All of these are mobilization or equipment-holding units in peacetime.

Reserve Training: In the Field Army, there are reserve training spaces (Wehrübungsplätze) designated solely for recalling reservists. In 1980, there were on the average 7000 of these spaces corresponding to more than 2.5 million reserve man-days. This number represents an increase of approximately 17 percent from earlier years. The Territorial Army will also increase reserve training. Consequently, there is a need for additional training areas, and about 1900 new areas will be built; bringing the total to 5900.

### Registration System<sup>1</sup>

It has been politically infeasible to assign all German residents with a person- or identification-number. However, all

---

<sup>1</sup>Major sources: (1) Interviews, Ministry of Defense, Staff, Department of Management and Justice/Conscription (VR III 7), Bonn, 24 September, 1980, (2) "Melderechtsrahmengesetz," (Registration Laws of 16 August 1980), Bundesgesetzblatt, Teil I, Nr. 50, 1980, and (3) Comments from OTL i.G. Ludwig, 12 December 1980.





<p>6 Heimatschutzbrigaden (similar to armoured infantry brigades)</p> 	<p>6 Heimatschutzbrigaden (equipment-holding units, similar to armoured infantry brigades)</p> 	<p>15 Heimatschutzregimenten (organized into 45 light infantry battalions)</p> 
<p><u>Readiness:</u> 4 brigades at 65 percent peacetime manning, one at 52 percent, and one at 85 percent.</p> <p><u>Mission:</u> Rear area security as well as forward defense in support of the Field Army.</p> <p><u>Manning:</u> Active duty officers and NCOs, enlisted (min. 4 years), and conscripts (min. 15 mos.). Reservists to man units to wartime levels. and to replace conscripts with less than three months training.</p>	<p>Mainly equipment-holding units mobilizable in three days (M+3).</p> <p>Rear area security, headquarters and logistics support, damage repair, and other support of the Field Army, etc.</p> <p>Active duty officers and NCOs assigned elsewhere in peacetime but recalled to wartime assignments during mobilization exercises and training. Former conscripts and other reservists assigned for up to six years after discharge from active duty.</p>	
<p><u>In addition:</u> (1) 150 security companies for defense of civilian targets of military interest.</p> 	<p>(2) 300 platoons assigned to defense of depots, airfields, etc.</p> 	

Fig. 10--The new Territorial Army

residents must report address-changes to local, civilian authorities (Gemeindebehörden) who are in charge of the registers (Melderegister). Address changes are reported to the military by the civilian authorities.

A law of 16 August 1980 (Melderechtsrahmengesetz) serves as the legal framework for the pertaining laws of the Länder for the national registration system. Local authorities are obligated to keep records (Melderegister) of all residents in their area. The data contained in the Melderegister are family name, earlier names, first name, academic degrees, aliases, birthdate, birthplace, sex, employed/not employed, basic information on legal guardian, citizenship, formal religious membership, present and former address, major and subsidiary residence, date of entry and exit into the region, marital status, basic information on spouse, basic information on children under legal age, date and place of identitycard/passport, and if relevant, date and place of death.

Military and civil defense authorities have limited access-- as spelt out in the law--to the information in the Melderegister and solely on those individuals under military obligation and to the degree the respective authorities need the information to perform their duty.

When the storing of information on an individual is no longer required by law, or if inadmissible information is stored, it must be destroyed.

By law, all German residents (except, for example, diplomatic personnel) must report address changes. Call-up for regular or reserve military service does not have to be reported. Voluntary, military personnel do not have to report temporary duty absences unless longer than three months.

At the age of 18, all young men are liable for military service and are requested to report for classification by the local authorities (Länderbehörden).

A reservist is requested to report all moves or job changes to military authorities. However, there exists no institutionalized registration system for updating either addresses or functional assignments on a regular basis. The military registration system is computerized, however, the civilian system is not yet computerized.

The 18,600 reservists in Verfügungsbereitschaft (stand-by reserves) must report even a contemplated move; i.e., these reservists are under obligation to keep the military authorities (Wehrersatzbehörden) at all times informed about their address.

Since no civilian identification number exists, all military personnel are assigned a soldier-number. This number, used solely by the military, consists of birthdate (six digits), first initial in the last name, a geographic region code (three digits), a serial number (Zählnummer/laufende Nummer), and finally, a single digit computer code. This soldier-number stays with an individual throughout the military obligation.

While on regular active duty, each soldier is also assigned one or several functional codes depending on the function(s) he is able to fill. This number is referred to as the Ausbildungs-und Tätigkeit Nummer (ATN; educational/training and functional number). There are several hundred functional categories, each having an eight-digit code. The ATN is normally never changed.

Civilian training received after discharge from regular active duty will rarely result in changing an individual's ATN. Only if requested or if given additional military training because of shortages in critical skills, may the ATN be changed. Certain civilian professional qualifications may also lead to a change in the ATN during a reserve recall (Wehrübung).

NORWAYBackground

Conscription has a long history in Norway. The Constitution of 1814, paragraph 109, assumed universal, compulsory service; however, inductions were for a long time limited to people from the countryside. In 1854 compulsory military service was introduced to include all men in a certain age category from both the cities and the countryside. The possibility to pay someone else to serve was limited. In 1876 a law on compulsory service was passed which eliminated the possibility of paying for a replacement. In 1897 conscription was extended to include also those living in North Norway.

Not all eligible males were inducted, and selection was done by lottery. However, in 1910 a new law was passed which no longer permitted selection by lottery.

After World War I, the trust in the League of Nations, the Norwegian neutrality policy, and the general environment of disarmament led to a rather drastic reduction in the armed services. Only about half of those eligible were inducted, and a progressive defense tax was imposed on those not having to serve. Selection was mainly done by setting strict physical standards.<sup>1</sup>

The existence of Norwegian troops created at home and abroad during World War II, eased the conversion from war to peace. The question of Norwegian participation in the occupation of Germany came up in 1946, and in 1947 the Parliament agreed that Norway, beginning in the spring of 1947, should station a brigade of 4000

---

<sup>1</sup>Verneplikt, NOU 1979:51 (Report by the Committee on Conscription), Oslo, July 18, 1979, Sec. 5.1.

men (mainly conscripts) in the zone occupied by the British. This arrangement lasted until 1953, when the need to redeploy these forces to Norwegian territory became apparent.<sup>1</sup>

The Norwegian system of conscription, therefore, is based on tradition and is supported by the Constitution, but it also reflects the experiences of World War II. It is seen as natural and acceptable and is regarded as a democratic form of building defense. Even so, the system is debated, with more selective conscription mixed with increased use of long-term volunteers as one alternative.

The Norwegian age cohorts are relatively small compared to the size of the wartime force. Therefore, there is little possibility of increasing force size by increasing the number of men inducted, rather the present wartime force is maintained by retaining men in reserve status for a prolonged period of time.

While the Norwegian wartime Army is by far the largest in NATO relative to the population base, there are complaints about the quality of equipment and about standing readiness.<sup>2</sup> The Defense Review Commission of 1974 suggested in their 1978 report that the standing and two mobilization brigades be changed from infantry to armoured brigades and that some mobilization units be replaced with standing units.<sup>3</sup>

---

<sup>1</sup>Major General Bjørn Christophersen, Forsvarets plass i norsk historie, Forsvarets Krigshistoriske Avdeling, Oslo, 1971, pp. 63-68.

<sup>2</sup>Fully mobilized, the Norwegian wartime forces constitute more than seven percent of the population. Corresponding figures for Denmark, the Federal Republic of Germany, the United Kingdom, and the United States are approximately 3.7, 2.7, 1.0 and 1.3. Outside NATO, the Swedish wartime armed forces constitute about 10 percent of the population, and the Israeli more than 11 percent of the total population (note: only Jews and Druses are under military obligation; Muslims and Christian Arabs may apply to join as volunteers).

<sup>3</sup>Forsvarskommissjonen av 1974, NOU 1978:9, Oslo, March 1978, Sec. 21.4.

## Manpower Procurement Policies

The major manpower procurement method in Norway is conscription, and the policy is likely to continue. Because of the need for a large defense effort relative to the population base, universal conscription is approximated. About two-thirds of each male cohort complete first-term regular active duty in one of the armed services, but about 90 percent perform some function within Total Defense.

Fig. 11 shows the manpower flows through the Norwegian ground forces.

Males are under military obligation from age 19 until 45.<sup>1</sup> If the country is threatened by war or is at war, men are under military obligation until age 55. Men ages 45 to 55 may also be under peacetime obligation for special Home Guard duty or in other Total Defense functions. Both men and women ages 18 to 65 may be required to serve in Civil Defense.<sup>2</sup>

The length of compulsory service is at all times determined by the Storting (Parliament) and has been changed several times since World War II. Currently, first-term regular active duty in the Army, the Air Artillery, and the Coastal Artillery is 12 months, and 15 months in the Air Force and in the Navy. The shorter term in the Army is offset by more reserve recalls. Exceptions to these terms are made when required to ensure obvious educational and other military requirements and to encourage voluntary enlistment which is compensated with higher rank and better economic compensation and fringe benefits.

---

<sup>1</sup>In 1946, the minimum age was lowered from 21 to 20 years, and in 1977 a gradual lowering to 19 was implemented.

<sup>2</sup>Håndbok for Soldaten: Haeren, UD 17-1, Oslo, August 1973, p. 10.

PEACETIME FORCE ( PLUS SOME ADMINISTRATIVE ELEMENTS OF THE MOBILIZATION COMPONENTS ).

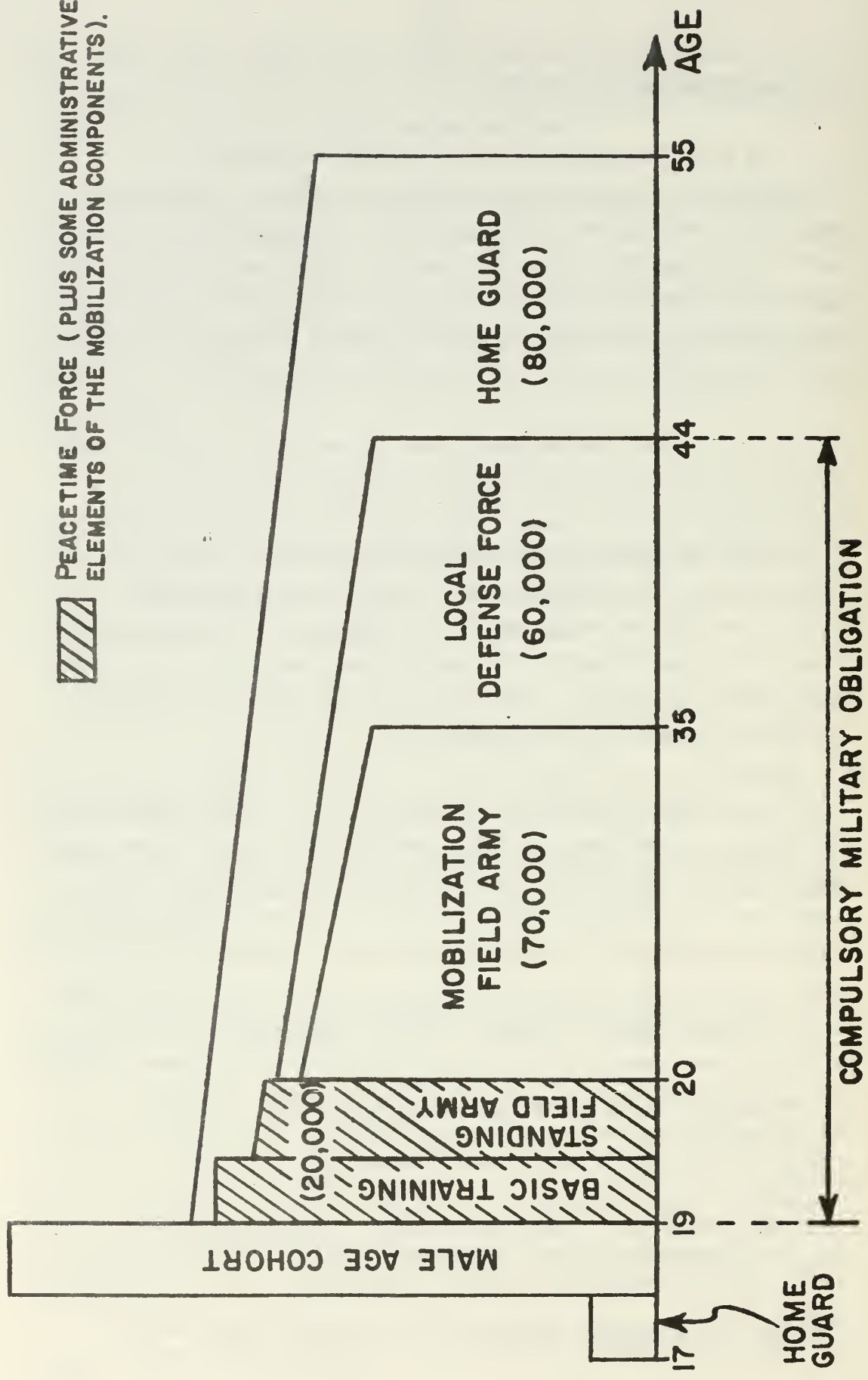

Fig. 11--Manpower flows through the Norwegian Ground Forces



Due to technological developments, requirements for skilled manpower have increased. The age cohorts currently eligible for induction have received better vocational training prior to military service than earlier.<sup>1</sup> Therefore, improved methods of utilizing manpower have been implemented. Previous civilian qualifications, competence, and wishes are taken into consideration.<sup>2</sup>

As mentioned, Army conscripts are initially drafted to 12 months regular active duty. Those who volunteer for NCO training receive sergeants rank and pay after 12 months theoretical and practical training, and are obligated to serve an additional 12 months.

Before 1969, the Army followed a 3+3+6 training pattern for all conscripts; i.e., 3 months basic training, 3 months unit training, 6 months in a standing unit. However, since 1969 it has been impossible to man all standing units with this pattern, and the Army changed to a 3+9 pattern; i.e., 3 months in basic training followed by 9 months in a standing unit. Those requiring specialty training may follow the old 3+3+6 pattern; i.e., three months basic training is followed by three months speciality training before transfer to a standing unit.

After the regular active duty period, conscripts are first assigned to the Mobilization Field Army until age 34 and thereafter to the Local Defense Force until age 45.

The refresher training pattern (amount and frequency) is also determined by the Storting. In 1980, the total annual man-day budget for recalling reservists in the Field Army and Local Defense Force, was approximately 310,000. The men in the "average" mobilization field unit are recalled 21 to 30 days every four years,

---

<sup>1</sup>Ministry of Defense, Tjenestetiden i Forsvaret, NOU 1972:32, Oslo, 1972, p. 73.

<sup>2</sup>This concept of "matching" civilian skills and qualifications with military requirements is known in Scandinavia as "the right man for the right job."

those in high priority field units, 21 to 30 days every three years. Because all conscripts do not serve the same number of days, Norway in effect operates under a system of differentiated length of obligatory service depending on the complexity or priority of the function. On the average, obligatory regular and reserve active duty for Army privates total 468 days, for specialists, 510 days. However, many conscripts volunteer for duty beyond the minimum obligation.

Enlisted volunteers serve a limited role in the Norwegian armed forces. With some exception, men who enlist voluntarily sign up for non-terminable three-year contracts. Reenlistment may take place twice, but not after they turn 34 years old. This policy has not been very successful or extensive. Mainly functions which provide civilian sector competence have been completely filled. The shortfall elsewhere has been partly offset by the improved quality of conscripts upon induction. Approximately ninety percent of reserve officers and NCOs are in conscript status. However, as will be discussed later, these have more than 12 months military training.

The lack of volunteers may result from more than 60 percent of all young men being drafted giving them a sense of having fulfilled their obligation. Given the incentives and the conditions of military service in Norway (North Norway being the most strategically exposed region and where the major part of the standing Army is deployed), the civilian sector may look more attractive than military service. The use of long-term volunteers would involve bringing families into North Norway where the economic and social infrastructure is minimal and where the climate and daylight conditions are rather extreme.

Voluntary enlistment has not been as cost-saving as initially expected. With the current incentive system, the available pool is small and not of desired quality, the educational opportunities used to induce volunteers has decreased the effective service time, and

there have been demands--partially met--by this group for shorter workday/week, longer vacations, greater fringe benefits, etc. To a great extent, these factors also apply to conscripts resulting in increased cost per effective man-hour.

### Peacetime and Wartime Ground Force Structure<sup>1</sup>

As mentioned, Norway's defense task is large relative to its population base; consequently, Norway has relied heavily on mobilization forces throughout the postwar period. Conscription, combined with the mobilization emphasis, is seen to provide good use of the nation's defense potential. The Total Defense concept, covering both military and non-military (civil defense, economic and psychological preparedness, police, civilian administrative authorities, etc.) defense, yields quantitative strength in case of war, prepares the country for other external pressures and crises like cut-off of vital imports, and limits the effort required in peacetime.

In contrast to the Danish system, the Norwegian demographic characteristics and the vulnerability of the communications system have made it necessary to organize the standing force into one complete basic operational unit (BOU); i.e., an infantry brigade. This brigade and smaller units, a total of 6500 men, are at all times deployed to the sparsely populated and strategically vulnerable North Norway.

North Norway is divided into four army districts under the Commander Allied Forces North Norway (COMMON). The defense districts are composed of standing forces, mobilization units, and Home Guard units. In addition, the 6th Division, a mobile division headquarters designed to command three to five brigades, is situated

---

<sup>1</sup>The Norwegian ground force structure, mobilization planning, and reserve training are discussed in great detail in: Ragnhild Sohlberg, Defense Manpower Policy Analysis: NATO Ground Forces, P-6532, The Rand Corporation, June 1980.

in North Norway. The largest unit in the standing force in North Norway is the standing brigade (BRIG N) deployed in Troms County. This brigade is situated in three main garrisons.<sup>1</sup>

The major features of the wartime organization are shown in Table 3. In contrast to Denmark, Norway has only one type of BOU. The infantry brigade, shown in Fig. 12, consists of approximately 5500 men organized as follows:

Command: Staff, headquarters company, military police platoon, signal company.

Maneuver units: Three infantry battalions, armoured reconnaissance company (cavalry).

Tactical support units: Artillery battalion, heavy mortar infantry company, anti-tank platoon, light air defense battery, engineer company.

Administrative support companies: Transport, supply, supply and maintenance, medical.

In addition, there are support units organically outside the brigade structure--e.g., armour, artillery, supply--assigned to the division command (3 to 5 brigades) according to availability and need.

As shown in Table 3, the Field Army consists of 12 infantry brigades, of which only one is standing. The remainder are mobilization brigades. Approximately 15 percent of the officers and NCOs are full-time professionals, normally assigned to Headquarters, Ministry of Defense, schools, and regiments in peacetime. The remainder, 85 percent of officers and NCOs, as well as all privates are reservists.

---

<sup>1</sup>COMMON, Velkommen til Øvelse ARCTIC EXPRESS 1978.

## NORWAY'S ARMY WARTIME FORCE STRUCTURE

Field Army (78,000)	Mobilization Force (130,000)	Local Defense Force (60,000)
Standing Force (8000)	Field Army Reserve (70,000)	
<p>Standing readiness (preparedness) units: 1 infantry brigade and smaller units.</p> <p>Deployment: 6500 men deployed to Northern Norway.</p> <p>Professional officers and NCOs. Conscript officers in training for mobilization functions.</p> <p>A few enlisted personnel on 3-year contracts.</p> <p>80% conscripts, avg. 20 yrs. who have completed at least 3 mos. basic training.</p> <p>Readiness: M-day.</p>	<p>Mobilization units: 11 infantry brigades and smaller units.</p> <p>Deployment: 4 brigades earmarked for N. Norway (2 raised locally); the remainder to be deployed as needed.</p> <p>Equipment: Similar or identical to the standing readiness units.</p> <p>Approximately 15% professional, full-time officers and NCOs, generally assigned elsewhere during peacetime; the remainder is conscript reserve officers.</p> <p>Discharged conscripts, ages 20-34.</p> <p>Ready and deployed: M + 2 days for high-priority brigades.</p>	<p>Mobilization units: battalions and smaller units.</p> <p>Deployment: Locally (or as needed)</p> <p>Equipment: Generally inherit from Field Army--"2nd generation."</p> <p>Discharged conscripts, ages 35-44.</p> <p>Readiness: M + 2 days.</p>
<p>Standing Force = Standing Readiness Units + Field Army Reserve + Local Defense Force (+ Home Guard--80%) (8000) + (70,000) + (60,000)</p> <p>= <u>138,000</u> (+ 64,000 = 202,000).</p>		

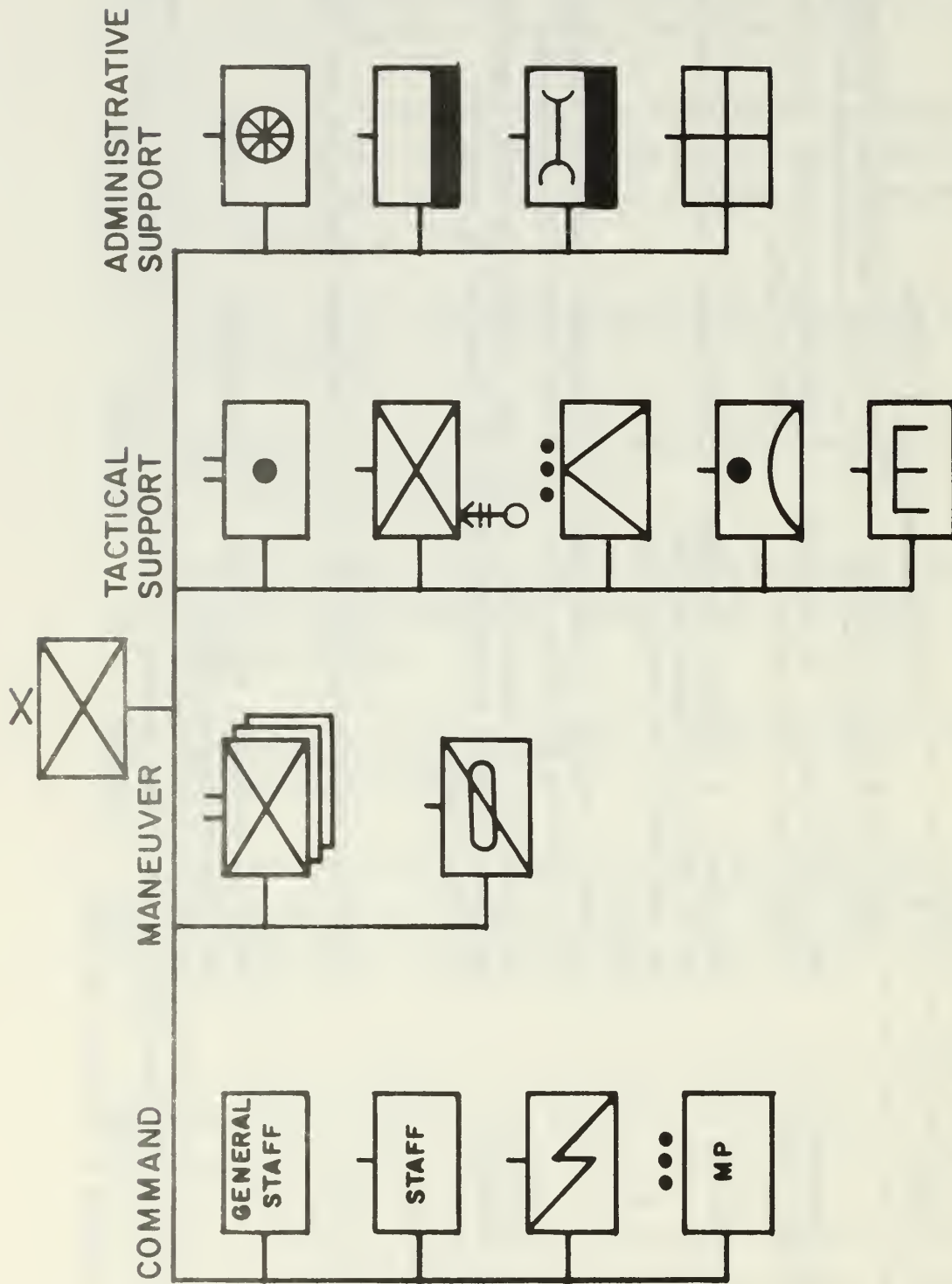

Fig. 12--The Norwegian Infantry Brigade

However, both because they have longer military obligation than the other ranks and because they often volunteer for extra training, all reserve officers have much more than 12 months military training. Many are also former full-time professional officers who obtain conscript (vernepliktig) status upon return to civilian life if this return takes place before the legal retirement age.

The peacetime organization of the Mobilization Force (Mobilization Field Army and Local Defense) consists of regiments. These regiments are administrative and caretaker units organized according to weapons. The wartime organization of the Mobilization Force draws units from the various regiments--e.g., infantry battalions from infantry regiments, artillery battalions from artillery regiments.

The number of full-time personnel in a regiment ranges between 40 and 50, approximately half of them civilians. The conscripts in the wartime units are drawn from the local population. Infantry regiments draw personnel from smaller areas than artillery regiments. Because the artillery units have more complex tasks, they recruit from a larger population base to get the best qualified personnel.

All 12 Field Army brigades are similarly organized and equipped. When the standing brigade receives new equipment or weapons, this is also procured for the mobilization brigades. Because trained personnel may not be immediately available in mobilization units, new equipment is phased in gradually as conscripts are transferred from the standing force or as reservists are retrained.

One of the high-priority mobilization brigades in South Norway is earmarked for early reinforcement of North Norway and has "dual based" equipment; i.e., this brigade has access to training equipment in South Norway as well as to another set prestocked in North Norway. The long-range planning goal is to prestock equipment

for additional brigades in this sensitive northern area while ensuring that these units also have a complete set locally in the mobilization area in case a transfer is undesirable or impossible.<sup>1</sup>

Brigade-level exercises take place at least twice a year, often in association with a full-scale airlift of one mobilization brigade from South to North Norway. During recent years, this transfer has taken place in association with NATO exercises which incorporate the Norwegian standing brigade, allied troops, and a Norwegian mobilization brigade--a total of about 15,000 troops.<sup>2</sup> These high priority exercises consume a substantial portion of the annual man-day budget for refresher training, leaving little for lower priority units.

The Local Defense Force, organized into battalions and smaller units, generally inherits equipment from the Field Army. Consequently, older personnel are familiar with the equipment and require little retraining. The emphasis during recalls, therefore, is on training skills and on exercises.

Like Denmark, Norway has a Home Guard. Recruitment is based on both conscription and volunteerism; however, most of the Home Guard members are under compulsory military obligation and have completed regular active duty in one of the armed services. The members are obligated to serve 50 hours or 6 days per year. The most commonly observed training pattern consists of one continuous week every

---

<sup>1</sup>Forsvarskommissjonen av 1974, op. cit., Sec. 21.4.38.

<sup>2</sup>A unique feature shared by Denmark and Norway is the attitude toward foreign bases and nuclear weapons. During the postwar period, as part of the general Nordic Balance, both countries adopted the policy of neither permitting foreign troops to be stationed on their soil in peacetime nor nuclear facilities to be established. However, preparations may be made in peacetime for receiving foreign troops in case of crisis. The Nordic Balance involves NATO membership for Denmark, Norway, and Iceland, and non-alignment for Sweden and Finland; Finland having a treaty of friendship and mutual assistance with the Soviet Union.



year. Officers and specialists are obligated to serve an additional 14 days every three years. In 1980, the reserve budget for the Home Guard was 297,000 man-days. It is expected that the majority of the Home Guard can be mobilized within hours. Units in North Norway are equipped with anti-tank weapons.

### Registration System<sup>1</sup>

Like all Scandinavian countries, Norway assigns person-numbers to all residents upon birth. This number includes birthdate, a birthplace code, and a male/female code. Regardless of residence, this number remains unchanged--even if moving abroad.

Immediately after a change of residence, all residents are legally obligated to report to the local authorities (Folkeregister) in the area they move to. If they plan to leave the country and take up residence temporarily or permanently abroad, this must be reported to the authorities where they reside, in order to get a "sailing permit."

All Norwegians under military obligation are assigned an identification number which does not currently correspond to or incorporate the person-number. There exists no political or legal obstacles for making these numbers identical. However, in spite of a desire to change the current system, funds have been lacking. Consequently, an address change reported to the Folkeregister is not automatically provided to the military--even though the military have access to the Folkeregister for tracing individuals.<sup>2</sup>

---

<sup>1</sup>Unless otherwise noted, Interview, Norwegian Defense Headquarters, Army Staff, Oslo, 19 September 1980.

<sup>2</sup>In Sweden, a resident filling out his Folkeregister form must check off whether or not he is under military obligation. If he is, then one copy is automatically sent to the military authorities.

All individuals under military obligation are obligated to keep their units informed about any change in residence, occupation, or health status. If planning to travel abroad, emigrate or take a job on a merchant ship sailing only on foreign ports, they must apply to their units for permission.<sup>1</sup>

In addition to this obligatory reporting system, the Norwegian military has an annual registration system for updating the information on all individuals under military obligation. Forms, sent out each January, request information on address, occupation, health, and other information relevant to their functional and unit assignment.<sup>2</sup>

## THE UNITED KINGDOM

### Background<sup>3</sup>

In the 18th Century, Britain only had a small army. From 1688 to 1792 Roman Catholics were barred from service, so Ireland was not yet the recruiting ground she became at a later date. By 1802 the military force under central command numbered approximately 151,000<sup>4</sup>.

The army was isolated from society, but this was not viewed as a bad thing. Neither France nor Prussia seemed to offer attractive models for the close integration of army and society to a people that wished to remain "free and unfettered."

---

<sup>1</sup>Inspector General of the Army, Håndbok for soldaten: Haeren, (Soldier's Handbook: The Army), UD 17-1, Fabritius & Sønner, Oslo, 1973, p. 155.

<sup>2</sup>For further details, see Sohlberg (1980), Chapter IV.

<sup>3</sup>Unless otherwise noted, for the period up to 1939, the major source is: John Gooch, Armies in Europe, Routledge & Keagan Paul, London, 1980, pp. 18, 45-47, 78, 81, 119-120, 188-189, 216-220.

<sup>4</sup>Sir J. W. Fortescue, History of the British Army.

Between 1859 and 1879, the armies of all the major states in Europe clashed in wars. By this time, the British army was one of the least modern in Western Europe. The army in India was a potent but not always successful force<sup>1</sup>. Out of these experiences came European ideas about the size, organization, and structure of armies; focused around a peacetime army ready for war.

Because Britain's troops had to cope with the control of an empire, it was virtually impossible for her to introduce large armies manned by short-service conscripts. There were fears about putting arms into the hands of "unreliable groups."<sup>2</sup> Also, there was no tradition of conscription and little likelihood of its being introduced. The British were also fearful about a large standing (permanent) army, a fear that was a major factor in deterring army size and, hence, the reductions which followed every war since 1660<sup>3</sup>. However, attempts were made to improve the quality of the army by making soldiering a respectable profession and by improving pay and conditions of service. The Army Enlistment Act of 1870 reduced service from twenty to twelve years, half of which was spent in reserve status. The Territorial Force succeeded the Volunteer Force in 1908 and became the Territorial Army in 1920<sup>4</sup>.

By the end of 1914, military set-backs during World War I significantly reduced the effectiveness of the Regular Army. The gap was initially filled by the Territorials as well as those who enlisted in 1914. In planning the 1916 campaign, it became apparent that the flow of volunteers into the Army would be insufficient to satisfy the requirement for 1.5 million men. It was slowly accepted

---

<sup>1</sup>Comments on paper by Mr. J. Pitt-Brooke, Defence Secretariat i4 (Service Personnel), Ministry of Defence, London, January 1981.

<sup>2</sup>This argument against conscription is used in many Third World nations today.

<sup>3</sup>Ibid.

<sup>4</sup>Letter, LCDR Richard M.S. Hart, Office of the Head, British Defence Staff, British Embassy, Washington, D.C., 24 April 1978, and comments from Mr. J. Pitt-Brooke, op.cit.

that conscription was the only means likely to result in the necessary numbers. Conscription was implemented, however, initially it applied only to unmarried men.

In 1918 and 1919 demobilization occurred partly to get the economy going again and partly because there was no need for such a large military force--in spite of increased overseas commitments. The depression did not hit the United Kingdom until the late 1920's, and by that time the army had been reduced to close to its pre-war strength.<sup>1</sup> Economy and imperialism, two opposing forces, did not lead Britain to extend conscription in peacetime. But if a future major war broke out, it was assumed that compulsory service would be introduced. The introduction of the aeroplane, however, allowed Britain a cheap way to play the role of a great imperial power for another two decades.

Throughout the 1920s and for most of the 1930s, therefore, the army was Britain's "Cinderella service," and it reverted back to its nineteenth-century role as imperial policeman. The events in Europe during the 1930s led Britain to concentrate on bombers and ships rather than on building an army for use in Europe. Only a small expeditionary force was prepared.

In 1938, the army concentrated on "Home defense and Imperial defense" rather than on cooperating with other nations in the defense of their territories. Only after the Munich agreement in August of that year did Britain face the hard reality that European commitments first and foremost meant a military presence.

On September 3, 1939 the first peacetime conscription act, the National Service (Armed Forces) Act, was passed. These measures, however, were too late. In total, the Army played a lesser part in World War II than in the first World War, and it was smaller in

---

<sup>1</sup>Comments from Mr. J. Pitt-Brooke, op.cit.

strength. This was partly caused by the heavy demands on industry by the Royal Air Force, the need to man anti-aircraft weapons, and the increase in administrative manpower.

In 1945 it appeared that Britain had taken note of the lessons of their history. In addition, the country had come under the standing obligation to deploy forces to the Continent, while earlier this had occurred only occasionally.<sup>1</sup> With the exception of the few months in 1939, Britain was for the first time experiencing National (Military) Service in peacetime.<sup>2</sup> On January 1, 1949, the main provisions of the National Service Act of 1947, later consolidated in the National Service Act of 1948, came into force. From that date on, eighteen-year old men were to be compulsorily enlisted for military service for a period of twelve months in addition to part-time service in years following. In 1950, at the onset of the Korean crisis, the term of obligatory service was raised from 18 months to two years.

During the 1950s, the British Army was stretched to the utmost. Due to its role on the Continent which had been added to the traditional one of imperial peace-keeping, it suffered under limited resources and heavy commitments. In order to improve equipment in the three services, the 1955 Statement on Defence announced a slight reduction in manpower.

The 1956 Statement on Defence talked of military demands which involved heavy charges on the balance of payments. The military establishment and its supporting industries also locked up a

---

<sup>1</sup>This currently constitutes the British Army of the Rhine (BAOR) plus the contingent in West Berlin, and part of the Royal Air Force.

<sup>2</sup>Another reason for maintaining conscription might have been the need to cut military spending to a minimum due to the preoccupation with economic recovery, the demands for increases in personal consumption, and the commitment to welfare programs.

sizeable proportion of the materials and manpower needed to keep British goods competitive in world markets.<sup>1</sup>

The Suez operation in 1956 emphasized the severe economic limits within which the British government had to operate, and by 1957 the need to retrench was evident. The Statement on Defence announced that Britain would go nuclear and emphasize a smaller, professional conventional force. This was not only for economic, but also for strategic reasons. It was held that the role on the Continent and the geographical position of the United Kingdom required a standing force. Militia or home defense forces could not contribute to the common defense. By 1962 the armed forces were to be reduced from 690,000 to 375,000 men, and this would permit the abolition of conscription. The Army's total strength was to be limited to 185,000 men.

In order to save uniformed manpower, the administrative overhead was to be civilianized to the highest degree possible. By 1976, civilian pay constituted approximately 17 percent of the total defense budget.<sup>2</sup> The British Army of the Rhine (BAOR) was also reduced from 80,000 to 55,000 men. After 1960 there were no further call-ups, and Britain was once more the only European nation without a "citizen army."

Britain had experienced a trend toward popular anti-authoritarianism and doubt about the national role. The Army was experiencing an identity crisis, there was a self-consciousness about service lifestyle, and doubts about opportunities for a second career. Some held that the decision to end conscription reflected electoral rather than strategic or economic considerations. However, these factors were probably not independent. Without

---

<sup>1</sup>Source: Sprout, Harold and Margaret, "Retreat from World Power," World Politics, Vol. 15, July 1963, p. 676.

<sup>2</sup>Defence Estimates 1977.

doubt, a large military establishment meant a heavy peacetime burden on the manpower and income of the country, and the overseas obligations had a significant negative impact on the balance of payments of a country so heavily dependent on imports.

In the past, Britain has experienced recruitment problems for her all-volunteer force. Reasons given for these problems include low birth rates in the 1950s, the tendency for boys to stay longer in school as a result of the increased demand for higher education, increased competition in labor markets, and better training opportunities in civilian sector employment.<sup>1</sup> In 1968 the Defence White Paper suggested that to combat these problems, it was required that fringe benefits and living conditions offered by the armed service be comparable with those in the civilian sector, and that a closer association between the civilian and military population be developed.

In 1969, it was announced that a new pay structure would be implemented. The 1969 proposal by the National Board for Prices and Incomes were based upon the new concept of the "Military Salary". This concept involved paying the servicemen a salary fully comparable to that of their civilian counterparts as well as setting the charges for food and accommodation at a realistic level comparable to those a civilian would face under similar circumstances. Also, an "X-factor" would be added to military pay. The "X-factor" is an amount paid to all servicemen over and above the comparable rate to compensate for the extra disadvantages of service life; e.g., the extra turbulence (frequent moves) involved. It is not intended to compensate for the hazards which servicemen may face.<sup>2</sup>

---

<sup>1</sup>Statement on the Defence Estimates, 1968.

<sup>2</sup>Comments on Paper by Mr. J. Pitt-Brooke, op.cit.

In 1969, a unique characteristic of the British military system was introduced; the recruitment of boys ages 15 to 17.<sup>1</sup> These Junior Soldiers could enlist for a term of service up to their 18th birthday, and thereafter in the regular military for up to 22 years.<sup>2</sup>

### Manpower Procurement Policies

Fig. 13 shows the manpower flows through the British Army. Since May 1, 1972 non-commissioned ranks can enlist for three to 22 years of service, with a wide freedom of choice on the length and terms of service. Recruits to non-commissioned ranks are committed for only a minimum period of service (about three years, excluding training) and, subject to that minimum, may leave after giving 18 months' notice. Commissions may be granted for short, medium, and long term. In all three services, there are opportunities for promotion from the ranks.<sup>3</sup>

Flexible options for regular soldiers were adopted to aid recruitment. However, manpower shortages continued in the 1970s. In 1977 and 1978, increasing numbers of experienced and well qualified officers and servicemen chose to leave prematurely. A prime cause was dissatisfaction with pay, but this was not all. The shortage, especially of skilled personnel, meant that the remaining manpower resources were overstretched, which in turn increased turbulence in the lives of service personnel and their families. Reorganization and the introduction of new equipment created additional demands.<sup>4</sup>

---

<sup>1</sup>Before the school-leaving age was raised from 15 to 16, boys could join at age 15.

<sup>2</sup>Major source: Col. Norman L. Dodd, "Future NCOs: The Junior Soldiers of the British Army," Military Review, February 1974, pp. 39-47.

<sup>3</sup>"Defence," Britain 1980, Chapter 4, pp. 92-93.

<sup>4</sup>Statement on the Defence Estimates, 1980, Vol. I, Secs. 604-605.



▨ Peacetime Force (plus some TA and UDR)

Note: Junior Soldiers and Cadet Forces do not figure in mobilization plans.

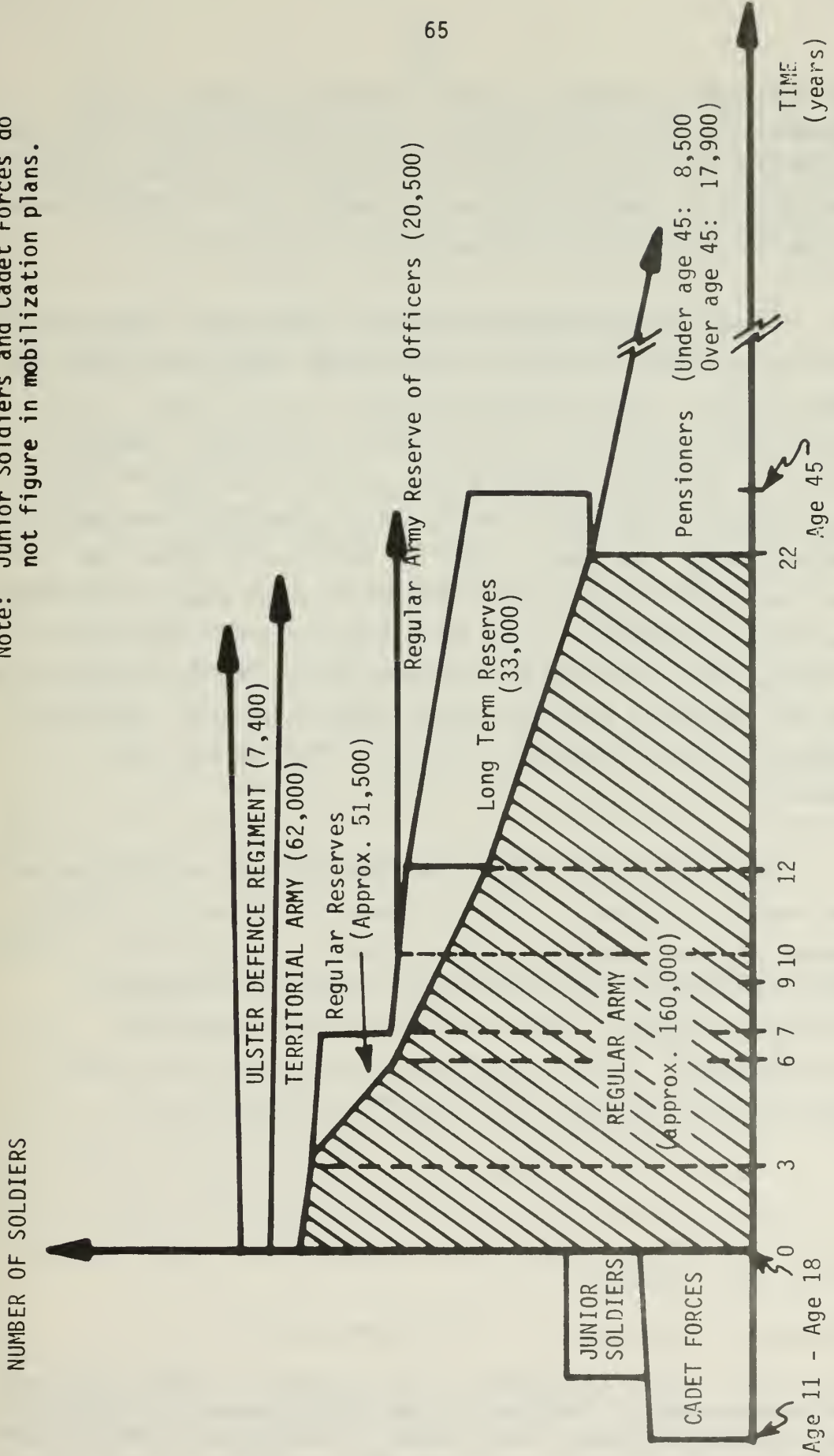

Fig. 13--Manpower flows through the British Ground Forces

The Government promised to restore the Service's pay to full comparability with that of their civilian counterparts. Recruiting in 1979/80 was generally good and improved after the pay award.<sup>1</sup> Recruitment in 1980/81 has been even better than in 1979/80, and it is now at record levels. Retention has also improved.<sup>2</sup>

In addition to the Junior Soldiers consisting of early school-leavers who later can enlist in the Regular Army, Britain also has Cadet Forces. Here school-boys between 11 and 18 years old can serve, and an interest in the military is developed. Some boys enlist in the regular forces after service in the Cadet Forces. Large number of Sea Cadets are now joining the Royal Navy and the Merchant Navy. The same is true for recruitment to the Army from the Army Cadet Force, but the expanded interest shown by young boys has not been reflected in the recruitment of Army Cadet Force officers, where there is still undermanning. The Air Training Corps and RAF section of the Combined Cadet Force continue to provide a valuable source of high quality recruits for the Royal Air Force.<sup>3</sup>

Today the British armed forces are dependent on civilian staff for support functions. They contribute to defense policy making, manage equipment projects, direct research and development programs, train servicemen in many essential skills, work in defense factories, shipyards, and in the research and development establishments. On the operational side, civilian staff help maintain Army vehicles, RAF's operational aircraft, etc.

---

<sup>1</sup>Ibid, Secs. 607-609.

<sup>2</sup>Comments on Paper by Mr. J. Pitt-Brooke, op.cit.

<sup>3</sup>Ibid, Sec. 622. For example, before a young man enters the Royal Military Academy at Sandhurst at age 18 as a potential officer, he may have been a member of his school's contingent of Combined Cadet Force. "British Army," op.cit., p. 83.

A total of 277,000 civilians are employed by the Ministry of Defence in 1980, of which 240,000 are based in the United Kingdom; constituting about one third of the Civil Service. A recruiting ban, however, was imposed from May to August 1979 throughout the Civil Service, a ban which also applies to the Ministry of Defence. Consequently, natural attrition reduced the number of civilian staff with possible negative implications for military support.

Reserves<sup>1</sup>: There are basically four categories of reserves in the British ground forces: (1) The Regular Reserves for soldiers, (2) Regular Army Reserve of Officers, (3) the Long Term Reserves, which was established in 1964, constitutes soldiers who have served between 12 and 21 years in the Regular Army and who remain in reserve status without pay until age 45, (4) Pensioners who are soldiers with a certain minimum length of service and who qualify for pension, are obligated for recall up to the age of 60 (at present this is not implemented beyond age 55, and there are plans to utilize only those with special skills), and (5) the Volunteer Reserve which comprises men and women, not necessarily with previous regular service, who have accepted liability for mobilization in an emergency.

The Individual Reserves include members from the Regular Army Reserve of Officers, Regular Reserves, Long Term Reservists, and Pensioners. All are liable for recall in case of mobilization, however, only the Regular Reserves have a training liability. These Individual Reserves provide a pool of men and women who have served as full-time regulars of the armed forces to use as individual reinforcements. As of January 1, 1980, the Individual Reserves numbered 131,400. The breakdown was presented in Fig. 13.

---

<sup>1</sup>Partly taken from, Statement on the Defence Estimates, 1975. Chapter IV (Reserve and Auxiliary Forces), p. 58, Paper given in the Ministry of Defence by Mr. Nicholas Bevan, Head of Defence Secretariat 7, and Comments on Paper by Mr. J. Pitt-Brooke, op.cit.

The Regular Army Reserve of Officers are officers having served at least 10 years in the Regular Army or TA, and who have a reserve obligation varying to between age 50 and 60 depending on their rank, length of service, and specialization.

The Regular Reserves consist of ex-service soldiers. Soldiers having served less than six years in the Army are automatically obligated to serve for a limited period in the Regular Reserves until their service time totals seven years (average 3 to 6 years). Soldiers having served more than six years are obligated to another six years in the Regular Reserves, a total of 12 years. Currently only men are under reserve obligation. However, there are plans to obligate also women for reserve duty.

The bulk of the mobilization requirements are provided by the Regular Reserves. This is natural because they have the most recent regular experience and are generally young and fit. This pool of Regular Reserves will be augmented with Long Term Reserves as well as with the younger Pensioners. In addition, a substantial number of retired officers will be called up. The role of this mobilized manpower will be to fill individual functions in Regular and TA units in order to bring these units to their full wartime strengths, to provide battle casualty replacements, and in the United Kingdom, to form small units for home defense tasks.<sup>1</sup>

The Volunteer Reserve constitutes members of the Territorial Army (before 1980, the Territorial and Army Volunteer Reserve; TAVR) and the Ulster Defence Regiment (UDR). These are mainly organized into units. Most of the personnel in the Territorial Army (TA) are young, non-prior service personnel; some of them civilians normally working in Ministry of Defence.

---

<sup>1</sup>Bevan, op.cit.

Members of the TA initially sign up for a three year period though they can in practice leave at any time. In order to earn the training bounty (payment) which is tax-free and ranges from 100 British pounds in the first year to 300 British pounds after three years, a soldier must attend a camp of 15 consecutive days (overseas every third year for those with a NATO role) and 12 other full days of training annually. The soldier can undertake more training voluntarily, and the goal is a norm of about 40 days annually. In addition to the bounty, the soldier is paid at Regular Army rates for each day's training.<sup>1</sup>

The TA units have a limited number of Regular officers and NCOs, permanently attached for training and administration. It is possible for a Territorial officer or soldier to serve for a year or 18 months in a Regular Army unit in BAOR or elsewhere, and then return to his TA unit without loss of seniority or promotion that would have accrued in his absence. In 1977, more than 20,000 TA members trained in BAOR and about 1000 elsewhere.<sup>2</sup>

The Volunteer Reserve has some problems. There are insufficient volunteers, they do not serve long enough, and all of them do not do enough training. For example, the TA is still some 10,000 men short of the target strength, and many soldiers serve less than three years. A recent improvement in bounty increased the strength by 4000 men. It is now higher than at any time since a major reorganization in 1967. In addition, the Prime Minister made a special appeal to employers whose cooperation is seen as essential in allowing staff time off for training.<sup>3</sup>

---

<sup>1</sup>Bevan, op.cit.

<sup>2</sup>"British Army," op.cit., p. 87.

<sup>3</sup>Bevan, op.cit.

## Peacetime and Wartime Ground Force Structure<sup>1</sup>

The strength of the British ground forces as of January 1, 1980, is shown in Table 4. Overviews over the deployment, organization, and structure are shown in Table 5 and Fig. 14.

The British ground forces consist of (1) the British Army of the Rhine (BAOR), (2) the Berlin Field Force, (3) the United Kingdom Land Force (UKLF) which includes the Territorial Army (TA) and Home Defence, and (4) the Ulster Defence Regiment (UDR).<sup>2</sup>

The main combat element of the BAOR is the First British Corps (1BR Corps). Together with the German, Dutch, and Belgian Corps, it is part of the Northern Army Group (NORTHAG) under the command of a British officer. After the reorganization announced in the 1977 Defence Estimates, the existing three infantry divisions were eliminated. Today the BAOR consists of four armoured divisions, one artillery division, and units of the 5th Field Force.<sup>3</sup> In an emergency, these forces would be reinforced from Britain by the remainder of the 5th Field Force, the 7th Field Force, other home based units (including some from the Territorial Army), Regular Army Reservists, and individuals from the Army's training and support organizations.

After full mobilization, the strength of the BAOR would be more than doubled, and up to 70 percent of the British Army would be in Central Europe under NATO command. The reserve and reinforcement forces are seen as essential to the ability of the BAOR to fulfill

---

<sup>1</sup>Source unless otherwise noted, Statement on the Defence Estimates, 1980, Secs. 306-310, 348-349.

<sup>2</sup>Letter from LCDR Richard M.S. Hart, op.cit., 14 April 1978.

<sup>3</sup>"British Army," op.cit., p. 82.

Table 4

THE UNITED KINGDOM: GROUND FORCES PERSONNEL<sup>a</sup>  
(January 1, 1980)

## THE ARMY

Male	153,100	
Female	<u>6,000</u>	
Total		159,100

INDIVIDUAL RESERVES<sup>b</sup>

Male	130,900	
Female	<u>800</u>	
Total		131,700

## TERRITORIAL ARMY

Male	57,700	
Female	<u>4,300</u>	
Total		62,000

## ULSTER DEFENCE REGIMENT

Male	6,700	
Female	<u>700</u>	
Total		<u>7,400</u>

TOTAL 360,200

<sup>a</sup>Source: Statement on the Defence Estimates, 1980, Vol. II, Tables 4.1 and 4.3.

<sup>b</sup>Due to differences in sources, the numbers in Fig. 13 and in the text differ slightly from those in this table. Present plans do not envisage calling out all of the Individual Reserves in case of emergency, rather, the numbers represent the size of the pool from which to draw. Some are not required, others have emigrated, are unfit or too old, or have left the service. Consequently, the actual number called up in case of emergency would be less than shown above. Source: Paper given in the MoD by Mr. Nicholas Bevan, the Head of Defence Secretariat 7.

Table 5

THE BRITISH ARMY<sup>a</sup>Deployment and Organization1. United Kingdom:

United Kingdom Land Forces (UKLF):

United Kingdom Mobile Force (UKMF)

6th Field Force with 5 (3 Reg., 2 TA) infantry battalions, etc.

7th Field Force with 3 Reg. and 2 TA units.

8th Field Force (3 Reg., 2 TA batt. for Home Defence).

1 batt. for ACE Mobile Force (Land).

1 SAS regiment

1 Gurkha infantry battalion

HQ North Ireland: 3 infantry brigades, HQS, 1 armoured reconnaissance regiment, variable number of major units in infantry role, 1 SAS, 3 engineering squadrons, 2 army aviation squadrons, and 1 flight unit.

2. West Germany:

British Army of the Rhine (BAOR): 1 corps HQ, 4 armoured divisions, 5th Field Force, 1 artillery division.

West Berlin: Berlin Field Force

## 3. The United Kingdom also has troops in Brunei, Hong Kong, Cyprus, Gibraltar, and Belize.

Reserves:

The Regular Reserves, The Territorial Army, The Ulster Defence Regiment.

---

<sup>a</sup>Source: The International Institute for Strategic Studies, The Military Balance 1979-1980, pp. 20-21. SAS= special air service. TA= Territorial Army. Reg.= Regular Army.



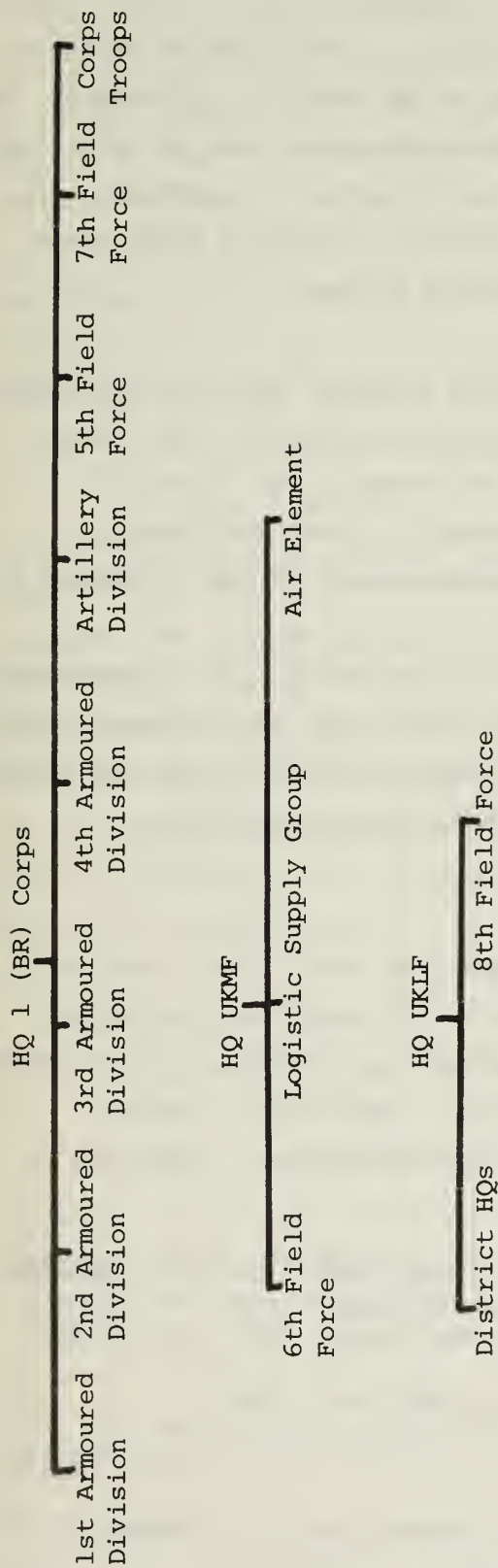

Notes:

- a. In peacetime, the 7th Field Force, part of the 5th Field Force, UKMF(Land), and all TA units come under command of HQ UKLF. After mobilization, the 7th Field Force, the balance of the 5th Field Force, TA units reinforcing all 1(BR) Corps formations and possibly UKMF will come under command of HQ 1(BR) Corps.
- b. All the above are Regular units, on mobilization reinforced by the TA.

Source: Commentary on Paper by J. Pitt-Brooke, Head, Defence Secretariat 14, Ministry of Defence, London, 15 January 1981.

Fig. 14--The British Army Force Structure

its wartime role. At any one time, some 3000 men from the BAOR are on short tours in Northern Ireland.<sup>1</sup>

The UKLF commands nine Army districts, while the HQ Northern Ireland is under the direct command of the Ministry of Defence. The Army districts command varying numbers of regular and TA units and those Field Forces based in the United Kingdom in peacetime. In case of tension, the units not deployed to reinforce BAOR would protect defense and other installations at home.<sup>2</sup>

The volunteer element of the Army reserve force is now known once again as the Territorial Army (TA). Strengths have risen sharply since the announcement of the change of title and of increased rates of bounty (compensation). Their equipment, organization, and missions are also in process of being changed.<sup>3</sup>

The TA is organized into two types of units: (1) independent units recruited from the local population, and (2) sponsored units and pools, which are specialists recruited from all over the country and sponsored by their own Army/Service Central Volunteer Headquarters.<sup>4</sup>

When the reorganization is completed, the TA will consist of 38 infantry battalions, 44 other major units, and 250 minor units. About 50 percent of the TA is committed to reinforce British troops in West Germany. Most of the TA units combine with regular formations to make up the 6th and 7th Field Forces, allocated to

---

<sup>1</sup>Ibid, Sec. 315. In 1977, Britain's total mobilization commitment to Europe was 78,000 Regulars and 60,000 Reservists. "Britain's NATO Army," NATO's Fifteen Nations, April-May, 1977, pp. 82-88.

<sup>2</sup>Statement on the Defence Estimates, 1980, sec. 348.

<sup>3</sup>Ibid, Sec. 619.

<sup>4</sup>Comments on Paper from Mr. J. Pitt-Brooke, op.cit., January 1981.

SACEUR as part of the UK Mobile Force (UKMF), with the bulk of the remainder forming the 8th Field Force (also with regular units) for defense of the United Kingdom.<sup>1</sup>

The TA units cover nearly the whole range of Army functions. There are armoured reconnaissance regiments, infantry battalions, engineer regiments, and artillery regiments as well as specialized units like transport, Special Air Service, and medical. The operational role of the TA are (a) to complete the order of battle of the British Army of the Rhine and to provide certain units in support of NATO HQs, and (b) to assist in maintaining the security of the United Kingdom home base.

According to current plans, approximately 70 percent of the TA would be deployed on the Continent in case of war. The TA is provided with equipment which is so far as possible identical to the equipment provided to regular units with the same role. Because of limitations on what part-time soldiers can do, TA units for example do not operate tanks. However, recent TA equipment issues include the BLOWPIPE air defense missile, the 105 mm light gun, and the latest CLANSMAN radios. Future plans include adding the MILAN anti-tank guided weapon.<sup>2</sup>

The UKMF consists of about 13,500 Regular and TA soldiers and includes one parachute battalion.<sup>3</sup>

The Ulster Defence Regiment (UDR) provides military support for the Royal Ulster Constabulary (RUC) in eleven Police Divisions in Northern Ireland.<sup>4</sup> The UDR, which is a part-time regiment, forms

---

<sup>1</sup>"UK improves terms of service for reservists," International Defense Review, No. 7, 1979, p. 1078.

<sup>2</sup>Bevan, op.cit.

<sup>3</sup>Statement on the Defence Estimates, 1980, Sec. 352.

<sup>4</sup>Statement on the Defence Estimates, 1980, Sec. 506.

an integral part of the Security Forces in Northern Ireland, and its duties include guarding key installations, manning checkpoints, and providing mobile patrols. In wartime, the UDR's function would be home defence. The recruitment of women to the UDR began in August 1973, and their primary task was to search women for explosives and weapons as well as to perform administrative work.

The UDR, an important regiment of the British Army, is organized into eleven battalions.<sup>1</sup> It provides a company-size force each weekend, available for deployment anywhere in Northern Ireland.

In addition to the organization already mentioned, Britain also has highly trained and well equipped ground forces as part of NATO's specialist reinforcements; some 1800 men assigned to Allied Command Europe Mobile Force (AMF), and forces for SACLANT whose deployment options include the reinforcement of Norway, Denmark, and the Atlantic Islands.<sup>2</sup>

In the context of a NATO war, mobilization (call-out) of reserves--both Volunteer and Regular--would be effected by means of a Queen's Order, in effect an administrative instrument. This Order does not require prior approval of the Parliament, and it becomes effective as soon as it is signed. Once signed, mobilization could be implemented either all at once or phased--depending on the situation. In the first instance, the Order would be announced through the media.<sup>3</sup>

---

<sup>1</sup>"Britain's NATO Army," op.cit., p. 87.

<sup>2</sup>Statement on the Defence Estimates, 1980, Secs. 350-353.

<sup>3</sup>Bevan, op.cit.

## Registration System<sup>1</sup>

It is not seen as politically feasible in Britain to introduce a national registration system and personal identification number for all residents.

Having no plans for registering or conscripting either males or females in case of emergency, British defense authorities expressed that they do not feel that the absence of a national registration system constitutes any military problem. The United Kingdom plans to fight wars with the same volunteer army they maintain in peacetime.<sup>2</sup>

A new mobilization scheme, making use of the peacetime training liability of the Regular Reserves and affecting the registration of reservists, will be introduced in November 1980 and be fully effective in April 1981. Under the old system, the Regular Reserves were simply required to report their whereabouts in writing every quarter, and when mobilized, to report to a central depot according to their regimental affiliation. No direct personal contact was maintained with these reservists in peacetime, consequently the system relied on self-reporting. However, there was a small incentive to report, between 18 and 35 British pounds (taxable).

Under the new arrangement, in exchange for a reporting grant of 100 British pounds (taxable), Regular Reserves are expected to keep a complete set of personal combat equipment (not including weapons) and uniforms at home, and will have to report in person to one of

---

<sup>1</sup>Major sources are (1) Interview, Ministry of Defence, Defence Secretariat 7/Service Personnel/Mobilization, London, 26 September 1980, and (2) Individual Reinforcement Plan (IRP), Press Release, Ministry of Defence, London, November 1979.

<sup>2</sup>A recent upsurge in public interest in conscription, is more for social (unemployment and "getting young people off the streets") than for military reasons. Daily Telegraph, December 29, 1980.

approximately 400 local Reporting Centers, one day a year for kit checks, medical assessment, and documentation updates. If necessary, introductory training for new personal weapons and procedures will be carried out.

Such ante facto equipping, training, and trade classification, together with the revised local reporting procedures, will materially improve the readiness and speed of reaction of the Regular Reserves. Initially, 50,000 reservists will be involved. It is hoped that reservists coming to the end of his Regular Reserve service will be encouraged to extend it, and that sufficient Long Term Reservists, selected Pensioners, and members of the Regular Army Reserve of Officers will volunteer to undertake the annual reporting liability and thus be more rapidly available for deployment in an emergency.

It is expected that the new arrangement will cut the Regular Reserves' mobilization time by 50 percent, and that both the Regular Reserves and the Territorial Army will be mobilized and ready for deployment within M+10 days.

### III. SUMMARY COMPARISON AND CONCLUSIONS

Little comparative work has been done on manpower policies and force structures in NATO Europe. Most prior studies have concentrated on the larger allies; West Germany, France, and the United Kingdom, and on their peacetime forces rather than on their wartime potentials. This approach led to nations being judged largely on their peacetime establishments while augmentation or reserve forces were largely ignored.

There exists no apparent evidence that NATO membership has significantly influenced these four nations' manpower policies and ground force structures. This study clearly shows that Denmark, the Federal Republic of Germany, Norway, and the United Kingdom have developed very different ground force structures with respect to both manpower policies and organization.

#### PEACETIME AND WARTIME ORGANIZATION AND DEPLOYMENT

Analysis of the ground forces of Denmark, the Federal Republic of Germany, Norway, and the United Kingdom illustrates that their contrasting arrangements are responses to different conditions of population density, terrain, and internal communications, as well as to differences in geo-strategic location, traditions, and defense missions.

Table 6 provides a summary overview of the four nations' ground force wartime potentials and the expected time-phased availability.

#### Denmark

Denmark, a small, densely populated, flat country with good means of transportation, expects a potential attack to take place anywhere. Its standing force is organized into units dispersed around the country. Because of the short distances involved, the

Table 6<sup>a</sup>  
GROUND FORCES MANPOWER

DENMARK (population 5,140,000)

Field Army

Standing Force.....	8,500	(all-volunteer)
Augmentation Force.....	<u>4,500</u>	(stand-by reserves)
Covering Force.....	13,000	
Covering Force Reserve.....	<u>12,000</u>	
Five brigades, etc.....	25,000	
Other Reserve Units.....	<u>29,000</u>	
Total.....	54,000	
<u>Local Defense Force</u> .....	24,000	
<u>Home Guard</u> .....	approx. 70,000	(mainly non-prior
<u>Personnel Replacement Depot</u> .....	<u>12,000</u>	service)
TOTAL GROUND FORCE WARTIME POTENTIAL.....	<u>160,000</u>	(M+3 days)
Percent reservists:	<u>approx. 90.</u>	
Percent of population in wartime ground force:	<u>3.1.</u>	

THE FEDERAL REPUBLIC OF GERMANY (population: 61,600,000;  
including West Berlin)

Field Army

Peacetime.....	275,000
Mobilizable.....	<u>165,000</u> (18,600 in stand-by reserve)
Total.....	440,000

Territorial Army

Peacetime.....	65,000
Mobilizable.....	<u>445,000</u>
Total.....	510,000
TOTAL GROUND FORCE WARTIME POTENTIAL.....	<u>950,000</u> (M+3 days)
Percent reservists:	<u>65.</u>
Percent of population in wartime ground force:	<u>1.5.</u>

(continued)

<sup>a</sup>Population figures are taken from The International Institute for Strategic Studies, The Military Balance 1979-1980, London, 1979. The remainder of the numbers are taken from the text.



Table 6 (cont'd)

NORWAY (population 4,090,000)Field Army

Standing Force..... 8,000

Field Army Reserve.....70,000

Total.....78,000

Local Defense Force.....60,000Home Guard (80 percent of 80,000).....64,000 (mainly prior  
service)TOTAL GROUND FORCE WARTIME POTENTIAL.....202,000 (M+2 days)Percent reservists: approx. 90.Percent of population in wartime ground force: 4.9.THE UNITED KINGDOM (population 55,960,000)Regular Army

Peacetime.....159,100

Individual Reserves.....131,700

Total.....290,800

Territorial Army..... 62,000Ulster Defence Regiment..... 7,400TOTAL GROUND FORCE WARTIME POTENTIAL.....360,200 (M+10 days)Percent reservists: 56.<sup>a</sup>Percent of population in wartime ground force: 0.6.

---

<sup>a</sup>Because not all Individual Reserves will be required or be available upon mobilization, this number constitutes an upper limit. It should be noted that the British Ministry of Defence also employed 277,000 civilians in 1980, many of them filling functions which elsewhere are performed by uniformed personnel.

Danes also expect to be able to rapidly augment the standing force. Therefore, the 8500 regular long-term volunteers in the standing force are used for manning high-priority combat units and key weapons and positions. The wartime Field Army is mainly organized into armoured infantry brigades.

### The Federal Republic of Germany

The Federal Republic of Germany, a partly flat, densely populated, and urbanized country, borders on sizeable Warsaw Pact potentials.<sup>1</sup> Allied forces are stationed in West Germany and have responsibility for certain sectors. West Germany itself has a Field Army and a well-trained, well-equipped Territorial Army. The latter remains under national command even in times of crisis and is tasked with support of Field Army units in forward defense as well as rear area defense tasks.

Field Army units and some Territorial Army units have high peacetime readiness. Field Army units will use reservists only for replacing personnel with little training, to man peacetime units to full wartime strength, and for individual replacements. The Territorial Army will use reservists to man peacetime units to wartime strength, to man equipment-holding units, and for individual replacements.

The Field Army is organized into relatively heavy units. Out of 36 brigades, 17 are armoured and 15 armoured infantry. A major part of the Territorial Army is organized into the equivalent of armoured infantry brigades, the remaining into light infantry battalions.

---

<sup>1</sup>The Soviet Union alone has a total Army strength of 1,825,000. Reserves (all services) total 25 million of which five million have served in the last five years. Soviet conscripts have a reserve obligation until age 50. Source: The International Institute for Strategic Studies, The Military Balance 1979-1980, pages 9 and 11.

## Norway

Norway's strategically weakest point is the sparsely populated north, an area located far from sources of either external or major internal reinforcements. Norway, therefore, has its 8000-man combat-ready standing force structured into both combat and support units, the bulk of which is deployed to North Norway at all times. Because the population is concentrated in South Norway where the chances of a surprise attack is believed to be smaller, its defense is based on mobilization units.

Having the largest proportion of the population of any NATO nation in the wartime ground force, Norway has its manpower mainly organized into infantry brigades. Attempts have been made to upgrade at least two to armoured infantry brigades, however, funds have not yet been made available for this purpose.

## The United Kingdom

The United Kingdom's primary mission is to provide forces for defense of Continental Europe. At all times, approximately one third of its Regular Army is stationed in West Germany; i.e., the British Army of the Rhine (BAOR) and the Berlin Field Force. In an emergency, these forces would be reinforced from Britain by Regular Army units, Regular Army Reservists, some Territorial Army units, and by individuals from the Army's training and support organization. After full mobilization, the strength of the BAOR would be more than doubled, and up to 70 percent of the Regular Army would be in Central Europe under NATO command. The remainder of the United Kingdom Land Forces are tasked with home defense or other NATO roles. A limited number of troops is stationed outside NATO territory. The British Regular Army is also rather heavily equipped, being mainly organized into armoured divisions.

Time-phased Availability

Table 6 showed that in the event of crisis, these four nations plan to mobilize a significant number of reservists. Denmark and Norway must mobilize approximately 90 percent of full wartime strength. Corresponding percentages for West Germany and Britain are 65 and up to 56, respectively.

The readiness level achieved by this mobilization potential, however, is probably matched only by a small portion of most nations' peacetime forces (ref. "effective force strength", Fig. 1). The United Kingdom expects to be fully mobilized within 10 days, while the other three nations expect to use only three days to reach full wartime potential.<sup>1</sup>

All reservists are not necessarily mobilized simultaneously. For example, Denmark and the Federal Republic of Germany have part of their reservists in stand-by status, implying that these men can be recalled without a regular mobilization declaration and are expected to be in place within one day. The three nations utilizing conscripts can also recall reservists within the budgeted man-days for reserve training without requiring a mobilization order. The Danish and the Norwegian Home Guards have as one main task to ensure a successful mobilization by directing traffic, protecting vital transportation links, depots, etc. These men can be mobilized within hours. All four nations' reservists are equipped with mobilization orders permitting phased call-up according to need.

Once mobilized, Norway and the United Kingdom face possibly the greatest deployment problems. Norway must lift some reserve reinforcements from South to North Norway, a distance which has few and vulnerable transportation links. To be effective, part of the

---

<sup>1</sup>An analysis of transition problems associated with mobilization as well as a detailed description of the Norwegian system is found in Sohlberg (June 1980), Chapter IV.

British Regular Army as well as reserve forces must be lifted from Britain to West Germany.<sup>1</sup>

## MANPOWER POLICIES

### Procurement Policies

Current manpower procurement policies reflect traditions. Except for the United Kingdom, these countries have retained conscription as a major manpower procurement method. Conscription was written into the Danish and Norwegian Constitutions. However, the West German Basic Law of 1949 had to be changed to allow a military, and in 1956 several laws referring to conscription were passed.

Peacetime forces: Denmark, the Federal Republic of Germany, and Norway--which to varying degrees have served as battlegrounds and are primarily concerned with territorial defense--have historically relied on conscription. A reduction or elimination of the conscripted component of military manpower has been debated, but in general the concept has wide acceptance and is seen as necessary and desirable.

In contrast, Britain's role, like that of the United States and Canada, has been to send expeditionary forces overseas. Only during and immediately after the two World Wars did the United Kingdom rely on conscription. For the last two decades, Britain has had an all-volunteer force.

The peacetime armies of Denmark and the Federal Republic of Germany have 30 and 51 percent conscripts, respectively. Consequently, their armies could be characterized as volunteer armies with conscript components. Norway, on the other hand, has 80 percent conscripts in the peacetime army.

---

<sup>1</sup>The British problem of having to deploy both peacetime and reserve forces to West Germany in case of crisis, is shared by the United States, the Netherlands, and Belgium.

In Denmark, only one third of each male age cohort completes regular active duty in one of the armed services. Corresponding numbers for West Germany and Norway are 58 percent and somewhat over 60 percent, respectively.<sup>1</sup> Approximately 90 percent of Norwegian male age cohorts serve somewhere within Total Defense. Universality in conscription, therefore, is only approximated if non-military Total Defense is included.

Reserve forces: None of these four nations recruit reservists directly into regular army roles. Men and women without prior service, however, may volunteer to the Danish Home Guard and to the British Territorial Army and the Ulster Defence Regiment. The Norwegian Home Guard consists mainly of prior-service personnel, but men and women may volunteer for service. Reservists in the West German Territorial Army have completed their regular active duty period in either the Field Army or the Territorial Army.

#### Regular and Reserve Policies

Table 7 shows the minimum regular and reserve obligation in the three conscript nations.

Denmark: Danish conscripts initially serve nine months in a Training Force, a period during which they have no wartime assignment and are trained for their reserve function. After this "apprentice period", they may volunteer for additional service in the Standing Force. If not, they enter reserve status for a maximum of 8 years. During this period they may be recalled when the mobilization system is tested or for short refresher training.

---

<sup>1</sup>France is another NATO nation attempting to approach universal conscription. However, never has more than two-thirds of each male age cohort been called up for military service. In the future, universal conscription will be even more difficult to approximate because between 1976 and 1980, 17 army regiments have, or will have been disbanded. Le Monde, January 31, 1980. Outside NATO, a high degree of universality in male military conscription is achieved in the non-aligned nations of Finland, Sweden, Switzerland, Yugoslavia, and Israel.

Table 7

MINIMUM MILITARY OBLIGATION<sup>a</sup>  
(Army only)

COUNTRY	REGULAR ACTIVE DUTY	RESERVE OBLIGATION <sup>b</sup>
Denmark	9 months	max. 8 years
The Federal Republic of Germany	15 months	max. 6 years
Norway	12 months	25 years

<sup>a</sup>Summarized from text. The United Kingdom, having only volunteers, enlists non-commissioned ranks from three to 22 years.

<sup>b</sup>The numbers refer to the actual peacetime obligation, a period during which the reservists may be recalled for peacetime reserve duty. In case of emergencies, the obligation can be extended according to current laws.

The Federal Republic of Germany: Of the three conscript nations, West Germany has the longest minimum regular military obligation. The 15 months regular active duty may take place in the Field Army or in the Territorial Army. Subsequently, they are in reserve status for a maximum of six years.

Norway: The majority of Norwegian army conscripts initially receive three months basic training in South Norway followed by nine months in the Standing Army in North Norway. Upon discharge, they are assigned reserve roles in the Field Army until age 35, followed by 10 years in the Local Defense Force. Reservists who are assigned to units earmarked for reinforcement of North Norway, also participate in mobilization exercises in the north.

The United Kingdom: The United Kingdom enlists non-commissioned ranks for periods lasting from three to 22 years. Soldiers having served less than six years in the Regular Army are obligated to assignment in the Regular Reserves until their service time totals seven years. Soldiers having served more than six years are obligated to another six years in the Regular Reserves. Britain also has Individual Reserves who constitute a pool of men to use as reinforcements and as individual replacements. The Volunteer Reserve consists of the Territorial Army and the Ulster Defence Regiment. Approximately 50 percent of the Territorial Army has a NATO role, and every three years these part-time soldiers participate in exercises in West Germany.

Reserve training: Currently available information on annual man-day budgets for recalling reservists in the various ground forces is presented in Table 8. Combined with the data in Table 7, one can conclude that West Germany has the relatively youngest conscripts in the wartime force. They have the longest regular training and apparently the most intensive reserve training.



Table 8

RESERVE TRAINING<sup>a</sup>

COUNTRY	SERVICES	ANNUAL MAN-DAYS
Denmark (1977)	Field Army and Local Defense Force	40,000 (incl. "alarm recalls" for Augmentation Force)
	Home Guard	Unknown (Obligation: Non-prior service personnel: 100 hours of basic training the first year, 50 hours annually during the second and third year, 24 hours annually thereafter).
The Federal Republic of Germany (1980)	Field Army	More than 2.5 million
	Territorial Army	Unknown
Norway (1980)	Field Army and Local Defense Force	310,000
	Home Guard	297,000 (all services)
The United Kingdom (1981)	Regular Army Reserves	One day annual reporting only for 50,000 reservists (to be increased).
	Territorial Army	Unknown (Commitment: Annual camp of 15 days overseas every third year for those with NATO commitment, and up to 16 additional days spread over the year)
	Ulster Defence Regiment	Unknown (Weekend recalls).

<sup>a</sup>Summarized from text.

Denmark also has a relatively young wartime force, retaining reservists for maximum eight years. However, they have only nine months regular duty and are rarely recalled for refresher training while in reserve status. Norwegian reservists tend to be older than those of the other three countries, but they are recalled regularly for refresher training. The British Regular Army Reserves generally receive no refresher training; however, they have a minimum of three years prior service. The majority of Territorial Army members have no prior service but receive annual training.

### Conclusions

Of these four nations, only the United Kingdom has an all-volunteer force.<sup>1</sup> Britain also has the smallest percentage of its population in the wartime force (see Table 6), women figure more prominently in its armed forces than elsewhere, and a significant number of defense functions are filled by civilians. On the other hand, Norway has the largest percentage of the population in the wartime force, the highest degree of universality in conscription, and the fewest long-term volunteers among the non-commissioned ranks.<sup>2</sup> One possible conclusion may be that manning an armed force which is large relative to the population base, may require conscription, but that a high degree of universality in conscription also deters voluntary long-term enlistments. In addition, in order

---

<sup>1</sup>Within the last two decades, the United Kingdom and the United States returned to their traditional all-volunteer force. However, in 1980 the United States reintroduced registration of young men for a possible future conscription requirement. Outside NATO, several nations which earlier had all-volunteer forces, are turning to conscription. For example, Jordan and Saudi Arabia are in the process of introducing or expanding conscription. Lebanon is planning to introduce conscription possibly by 1982 (the earlier decision to introduce conscription in 1979 was delayed). Malaysia and the Republic of South Korea are studying the possibilities for introducing conscription.

<sup>2</sup>Fully mobilized, Norway has more than seven percent of the population in uniform. Outside NATO, greater percentages are observed, for example, in Sweden and in Israel.

to man even a relatively small defense sector solely with volunteers, it may be necessary not only to offer substantial financial incentives, but also to enlarge the available manpower pool by offering women an expanded military role and to "civilianize" as many defense functions as possible.

It is clear that the concept of mass armies manned by inexperienced conscripts no longer holds for the four study nations. The conscripts are better qualified upon induction, the training period is used more efficiently, and the cost-effectiveness of soldiers over both the regular and reserve period is considered. In addition, part of the conscripted component consists of "quasi volunteers"--many have either been obligated to or have volunteered for training over and above the minimum. In addition, the amount of reserve training received by an individual depends on the priority of the function, whether new equipment has been introduced or not, etc. In reality, therefore, conscription does not necessarily imply equal service for all young men.<sup>1</sup>

Attempts to approximate universal conscription combined with prolonged reserve obligations may result in relatively inflexible or rigid force structures. For example, the Norwegian ground forces have remained basically unchanged over the last thirty years. This continuity certainly has advantages because the system, and in particular the mobilization system, has been refined over the years. However, as the environment and military technology changes, manpower policies along the lines of those observed in Norway, may inhibit changes that would otherwise have been made. The other three study nations have a much larger proportion of long-term

---

<sup>1</sup>Sweden and Egypt are examples of two nations with differentiated service for conscripts. Sweden assigns the longest service obligations to men with the most (useful) civilian education or training. In contrast, because the Egyptian military also has an important function in developing the nation's manpower, males with less than high school serve three years, those with high school two years, and university graduates serve only one year.

volunteers and retain reservists for a much shorter period of time. Consequently, it is much easier for the latter three nations to implement organizational changes and to introduce and adapt to new technology. Denmark drastically changed its ground force structure and policies in 1973, West Germany in 1979, and the United Kingdom when it eliminated conscription, as well as in later years.

While Norway, for example, may require a high degree of universality in conscription to take care of the large defense task relative to the population, the danger certainly exists that universality may predominate and take attention away from major military objectives.

Utilization of conscripts has changed over the postwar period. Some of the adjustments reflect civilian sector developments. First, the average European conscript has received better and more relevant training and education prior to induction than ever before, and the armed services have taken advantage of this. On the other hand, the soldiers also demand better living conditions, training relevant to their return to the civilian sector, and better compensation and conditions while in the military. As a result, the cost per unit of effective time of a soldier has increased and served to offset (some of?) the advantages of improved civilian training.

Other adjustments in utilization reflect military sector developments. Military technology is increasingly more sophisticated and requires more extensive training for operation or for maintenance. This has led to an increased use of longer term volunteers and conscripts with extended obligations, who are then given the more complex tasks.

Women have a limited role in the armed services of all these nations, but figure most prominently in the British all-volunteer forces. Because male age cohorts are shrinking as 1990 is

approached, the conscript nations are also looking into an expanded role for women in the regular armed services. None of these nations currently obligate women for mobilization assignments upon completion of regular service. However, in some cases they may volunteer for mobilization roles.<sup>1</sup>

Extensive reliance on civilian sector resources in case of crisis, the concept of a Total Defense service obligation, as well as (equitable) conscription may require a well-functioning national and military registration system. Of the four study countries, only Denmark and Norway have national registration and identification numbers for all residents and have regular (annual) contact with all reservists for updating addresses, health status, occupation and training, etc. The other nations have regular contact only with some reservists, the remainder of the reserve system relying on self-reporting.

The Danish, West German, and Norwegian reliance on mobilization forces are to varying degrees supported by the Total Defense concept whereby manpower as well as other civilian sector resources can legally be requisitioned in a crisis, and by a ground force structure with graduated responsibilities to ensure a successful mobilization. For example, Norway and Denmark have Home Guards which can be mobilized within hours, and their primary task is to ensure successful mobilization.

---

<sup>1</sup>A West German comparative study of the role of women showed that women are assigned combat roles only in Algeria where there are female fighter pilots. Elsewhere, women may receive some combat training, but mainly intended for self-defense or, outside NATO, for defense of their place of employment (industrial defense).

CONSEQUENCES OF DIVERSE MANPOWER POLICIES AND FORCE STRUCTURES

The diversity of manpower policies and ground force structures demonstrated in this study requires consideration in Alliance joint equipment procurement programs, in military balance assessments, and in force reduction negotiations.

NATO Coordination of Equipment Procurement

Rationalization, standardization, and interoperability (RSI) are promoted as means to improve the efficiency with which NATO's resources are being used. However, the diversity of manpower policies and ground force structures observed in NATO may limit both the feasibility and the desirability of many forms of standardization. It is also possible that diversity in some areas means strength rather than weakness.

Countries vary with respect to reserve augmentations, the use of reservists, and in the length of reserve obligation. There are great variations in military experience, in the interval since regular active duty, and in reserve training patterns. Therefore, the time required to fully introduce new equipment will vary from nation to nation. Differences in reliance on reserve augmentations also result in variations in the proportion of equipment stored and only used for reserve exercises. Consequently, equipment replacement rates also vary from country to country.

Technological developments have influenced force structures and manpower policies, but manpower policies and practices have also influenced the technological standard (level and complexity) selected for the ground forces. For example, much of the equipment in Norwegian ground forces is selected for ease of training, and older technology is passed on to forces with older reservists to

reduce the need for retraining and upgrading of skills.<sup>1</sup> Topography, climate, and soil conditions also put requirements on technical characteristics.<sup>2</sup> Standardization, therefore, may require manpower changes, modifications in the standardized component itself or in complementary items, or other policy changes. The net effect to NATO, therefore, may be uncertain.

Any discussion or evaluation, therefore, of introducing standardized equipment in NATO must take the diversity of policies and practices into consideration.

### Military Balance Assessments and Force Reduction Negotiations

The observed differences in manpower policies and force structures also raise doubts about how to sum the NATO parts and about the meaning attached to NATO/Warsaw Pact comparisons as they are usually presented.

This study provided additional evidence that the numbers provided by current, standard comparative defense publications are insufficient for a comparison of wartime force capabilities in NATO, for a comparison of NATO/Warsaw Pact capabilities, or as a baseline for meaningful force reduction negotiations. Traditional measures like defense budgets, aggregate manpower numbers, length of regular active duty, etc. should be interpreted in light of qualitative differences.

A study along the lines of the present one should also be done for other NATO nations and for Warsaw Pact nations. Data required

---

<sup>1</sup>The evidence provided in this study also indicates that the larger the ground forces are relative to the population, the more lightly equipped are the units.

<sup>2</sup>For example, West Germany decided that topography and the good communication links permit wheeled rather than tracked artillery units.

include at least the following: pre-induction training relevant to the military sector, length of regular active duty, length of reserve obligation and the pattern (frequency and duration) of actual rather than obligatory reserve training, length of total military obligation (regular plus reserve), relationship between civilian sector training or occupation and military functional assignment, the unit structure of the forces, the role of conscripts and volunteers and of regular active and reserve manpower in the wartime organization, the time-phased availability of wartime strengths, and the degree to which defense functions are manned by civilians.

A multi-dimensional assessment of manpower policies and manpower dimensions of ground force structures, is complicated, costly, and time-consuming, but it results in a more meaningful evaluation of military balances than an assessment of only readily available numerical measures.



REFERENCESDENMARK

- Chief of Defense, Handout on Danish Defence Organization, Vedbaek, June 1974.
- Chief of Defense, Tasks and Organizations, etc., Handout on Danish Armed Forces, Vedbaek, June 1975.
- Chief of Defense, The Danish System for Employment of Regulars, Handout on Danish Armed Forces, Vedbaek, June 1975.
- Chief of Defense, Forsvarschefsskitse 1975, Vedbaek, 1975.
- Chief of Army, Grundbog for Menige: Hjemsendt (Information for privates: Sent Home), No. 7, Denmark, 1976.
- Danish Defence Command, Press- and Information Service, Fakta om Forsvar (Facts about Defense), Vedbaek, January, 1978.
- "Danish Armed Forces Plan for the 1980's," International Defense Review, No. 2, 1980, p. 167.
- Defense Command, Dansk Forsvar af i Dag (Today's Danish Defense), Vedbaek, October 1977.
- "Dansk Brigad" (Danish Brigade), Arménytt, No. 4, Sweden, 1980.
- Facts About Denmark, Politikens Forlag, Copenhagen, 1972.
- Interviews, Danish Defence Command, Army Staff, Vedbaek, March 1978 and letter and comments, 26 April 1978.
- Minister of Defense, Bilag 2 til forsvarsministerens skrivelse af 15. marts 1977 (Appendix 2 to the Defense Minister's report of 15 March 1977), Copenhagen, March 15, 1977.

THE FEDERAL REPUBLIC OF GERMANY

- Force Structure Commission of the Government of the Federal Republic of Germany, The Force Structure in the Federal Republic of Germany: Analysis and Options, Bonn, November 28, 1972.
- Interviews with and letters and comments from OTL i.G. Gerhard Ludwig, Ministry of Defense (FÜ S IV 2), Bonn, during the period November 1978 and December 1980.
- Interviews, Ministry of Defence, Joint Staff/Organization (FÜ S IV 2), Bonn, 22-23 September, 1980.

THE FEDERAL REPUBLIC OF GERMANY (continued)

Interviews, Ministry of Defence, Staff, Department of Management and Justice/Conscription (VR III 7), Bonn, 24 September, 1980.

"Melderechtsrahmengesetz," (Registration Laws of 16 August 1980), Bundesgesetzblatt Teil I, Nr. 50, 1980.

Ministry of Defence, Die neue Struktur des Heeres (The new Army Structure), Press release, Bonn, November 7, 1978.

The Federal Minister of Defence, White Paper 1975/76: The Security of the Federal Republic of Germany and the Development of the Federal Armed Forces, Bonn, January 20, 1976.

The Federal Minister of Defence, White Paper 1979: The Security of the Federal Republic of Germany and the Development of the Federal Armed Forces, Bonn, September 4, 1979.

"Ny västtyska arméorganisation," (New West German Army Organization), Arménytt, Sweden, March 1979, pp. 16-18.

Ziemke, Earl F., "West Germany's Security Policy," Current History, May 1972, pp. 239-264.

NORWAY

Christophersen, Major General Bjørn, Forsvarets plass i norsk historie (The situation of defense in Norwegian history), Forsvarets Krigshistoriske Avdeling, Oslo, 1971.

Defence Commander North Norway (COMMON), Velkommen til øvelse ARCTIC EXPRESS (Welcome to Exercise ARCTIC EXPRESS), Norway, 1978.

Forsvarskommissjonen av 1974 (The Report of the Defence Review Commission of 1974), NOU 1978:9, Oslo, March 1978.

Inspector General of the Army, Håndbok for soldaten: Haeren (Handbook for the soldier: the Army), UD 17-1, Oslo, August 1973.

Interview, Norwegian Defense Headquarters, Army Staff, Oslo, 19 September 1980.

Interviews in Washington, D.C. and Oslo, and letters and comments from LTC Birger Setsaas, Defence Command Norway, Army Staff, during the period 1975 to 1980.

Ministry of Defense, Tjenestetiden i Forsvaret (Service length in Defense), NOU 1972:32, Oslo, 1972.

Verneplikt (Conscription), NOU 1979:51, Report by the Committee on Conscription, Oslo, July 18, 1979.

THE UNITED KINGDOM

"Britain's NATO Army," NATO's Fifteen Nations, April-May 1977, pp. 82-88.

Commentary on Paper by Mr. J. Pitt-Brooke, Defence Secretariat 14 (Service Personnel), Ministry of Defence, London, January 1981.

Daily Telegraph, December 29, 1980.

"Defence," Britain 1980, Chapter 4.

Dodd, Col. Norman L., "Future NCOs: The Junior Soldier of the British Army," Military Review, February 1974, pp. 39-47.

Gooch, John, Armies in Europe, Routledge & Keagan Paul, London, 1980.

Individual Reinforcement Plan (IRP), Press Release, Ministry of Defence, London, November 1979.

Interview with Brigadier W. L. Whalley, BAOR, in Monterey, California, September 10, 1979.

Interview with Staff from Defence Secretariat 7, Service Personnel/ Mobilization, Ministry of Defence, London, 26 September 1980.

Letter from LCDR Richard M.S. Hart, Office of the Head, British Defence Staff, British Embassy, Washington, D.C., 24 April 1978.

Paper given in the MoD by Mr. Nicholas Bevan, the Head of Defence Secretariat 7, Ministry of Defence, London, (1980?).

Slessor, Sir John, "British Defense Policy," Foreign Affairs, Vol. 35, No. 4, July 1975, pp. 551-563.

Sprout, Harold and Margaret, "Retreat from World Power," World Politics, Vol. 15, July 1963, p. 676.

Statement on the Defence Estimates, 1968, London, 1968.

Statement on the Defence Estimates, 1975, London, 1975.

Statement on the Defence Estimates, 1977, London, 1977.

Statement on the Defence Estimates, 1980, Vols. I and II, London, 1980.

"UK improves terms of service for reservists," International Defense Review, No. 7, 1979, p. 1078.

General

The International Institute for Strategic Studies, The Military Balance 1979-1980, London, 1979.

Sohlberg, Ragnhild, Defense Manpower Policies in Northern and Central European NATO, N-1314-MRAL, The Rand Corporation, Santa Monica, February 1980.

Sohlberg, Ragnhild, Analysis of Ground Force Structures on NATO's Northern Flank, N-1315-MRAL, The Rand Corporation, Santa Monica, February 1980.

Sohlberg, Ragnhild, Defense Manpower Policy Analysis: NATO Ground Forces, P-6532, The Rand Corporation, Santa Monica, June 1980.

Sohlberg, Ragnhild, Manpower Procurement Policies, Ground Force Structures, and Registration Systems: Denmark, The Federal Republic of Germany, Norway, and the United Kingdom, Defense Resources Management Education Center (DRMEC), Discussion Paper Series Number 1-81, Monterey, January 1981 (superseded by this paper).

## DISTRIBUTION LIST

Defense Technical Information Center Cameron Station Alexandria, VA 22314	2
Defense Resources Management Education Center Code 64 Naval Postgraduate School Monterey, CA 93940	385
Office of the Assistant Secretary of Defense, Manpower, Reserve Affairs and Logistics The Pentagon Washington, D.C. 20301	100
Library Naval Postgraduate School Monterey, CA 93940	2
Office of Research Administration Code 012A Naval Postgraduate School Monterey, CA 93940	1
Professor Ragnhild Sohlberg Code 6423 Naval Postgraduate School Monterey, CA 93940	10

U196238



DUDLEY KNOX LIBRARY - RESEARCH REPORTS

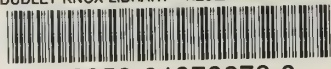

5 6853 01070278 0

0196238